



INSTALLATION & OPERATION MANUAL

EXPLORE SERIES E6 & E7 XFM



Preface

READ AND FOLLOW ALL INSTRUCTIONS IN THIS MANUAL

 **CAUTION**
(Risk Group 2): Possibly hazardous optical radiation emitted from this product. Do not stare at the operating lamp. Maybe harmful to the eye.

 **WARNINGS**
Before installing your OceanLED Light, read and follow all warning notices and instructions which are included. Failure to follow safety warnings and instructions can result in property damage, severe injury or even death.

Before installing your OceanLED Light, check local laws for restrictions regarding the use of coloured lights in your area.

Do not operate lights out of water for a period longer than 5 minutes followed by an OFF period of at least 1 hour. Exceeding this may cause damage to the light unit.

Ensure the bonding point of the light is fitted to the cathodic protection system on the vessel. Check conductivity between earth bonding point and aluminium bronze front bezel. If mounting the light to metal, carbon fibre or wooden hull, ensure that suitable measures have been put in place to account for the effects of galvanic corrosion or wood deterioration, i.e., use of Delrin sleeve components (Isolation Kit).

Salt is an inherently corrosive material. Metal parts and certain natural and man-made surfaces are particularly susceptible to corrosion and deterioration when used in and around saltwater. Some OceanLED lights contain combinations of plastic and polymer products which are impervious to saltwater corrosion, however, screws and fasteners used for the installation must be of a marine grade type stainless steel or equivalent and monitored annually to ensure the lights remain in service for years to come.

Never connect/disconnect lights with power applied as irreversible damage may occur. Ensure polarity of power connections is correct. Failure to do this may invalidate the warranty.

Ensure front of lights are always fully submerged and not fitted on planning / running surfaces that may impact on water since this may damage the product. Also ensure the rear of the light is in a dry area and not subject to a wet environment. Failure to do this may invalidate the warranty.

Never Use Solvents! Cleaners, fuel, and other products that may contain strong solvents, such as acetone, that attack many plastics greatly reducing their strength and irreversibly damaging the special lens coatings and cable sheathings.

Never clean lights using a high-pressure jet wash.

Remove the protectors from the connectors on the rear of the light ONLY if the connector will be used immediately. If the connectors on the light(s) are not in use, leave protector(s) on.

 **DANGER**
RISK OF ELECTRIC SHOCK OR ELECTROCUTION

This underwater light must be installed by a licensed or certified electrician in accordance with all applicable local codes and ordinances. Improper installation will create an electrical hazard which could result in death or serious injury to swimmers, installers, or others due to electrical shock, and may also cause damage to property. Always disconnect the power to the light at the circuit breaker before servicing the light.

Contents

1 Installation Checklist.....	3
2 Overview.....	4
3 Preparing The Hull	5
4 Installation.....	6
4.1 Installing The Light Fixture (Hull Thickness Up To 55mm).....	6
4.2 Installing The Light Fixture (Hull Thickness Above 55mm)	10
4.3 Installation Of Optional Rear Enclosure	12
4.4 Installation Of Explore AC Power Kit.....	13
4.5 Installation Of Explore DC Power Kit	15
4.6 Control System Installation.....	17
4.7 Finalising The Installation	21
4.8 Test Your Installation.....	21
5 Operation / Maintenance	22
5.1 Operation	22
5.2 Maintenance	22
5.3 Replacement Parts	23
5.4 Light Cartridge Removal – Single Mounting Tube	23
5.5 Light Cartridge Removal – Extended Mounting Tube	24
5.6 Light Cartridge Installation.....	25
6 Troubleshooting.....	27
6.1 Troubleshooting Problems And Their Solutions	27
7 Appendix.....	31
7.1 Overall Dimensions	31
7.2 Essential Test	32
7.3 Light Setup.....	33
7.4 Cable Gauge Chart 12V	35
7.5 Cable Gauge Chart 24V	36
7.6 Explore E6/E7 XFM Angled Beam Details.....	37
7.7 Example Of The DC Installation Of Mixed XFM And TH E6 & E7 Lights.....	38
8 Warranty	39

PRETEST

Always test the lights prior to installation. Failure to do this may result in additional installation time and could invalidate the warranty.

IMPORTANT NOTICE

Attention Installer: This manual contains important information about the installation, operation and safe use of this product. This information should be given to the owner and/ or operator of this equipment.

WARRANTY COVERAGE

Please refer to www.oceanled.com/warranty for full warranty statement.

1 Installation Checklist

1. Decide on light spacing – OceanLED recommendations available.
Rear of lights must never be exposed to wet environments inside the hull.
2. Decide on light angles (only applies for E7 installs) – OceanLED Personalised Service available on request.

The Explore E6/E7 XFM lights can also be mixed with the Explore E6/E7 TH – Please refer to Appendix Section 7.7 for the installation example.
3. Ensure the correct power kit is selected and installed (AC or DC power kit).
4. Ensure correct cable gauge is used (refer to relevant cable gauge chart).
5. Control system chosen (switch control, OceanLED DMX control kit, 3rd party DMX control)
Max 32 lights per DMX chain (as per recommended by the DMX standard).
6. Correct length light fixture chosen (Extension kit required for hulls thicker than 55mm).
7. Preparing the hull (Isolation kit required for conductive hull materials or wooden hulls).
8. Ensure the lights have been fitted in the correct orientation, and for E7, also with the correct beam angle.
9. Correct marine sealant applied evenly around the bezel. Ensure fully watertight seal is created after sealant cures.
10. Correct clamping of light fixture onto hull. Never leave vessel unchecked for a few days after install.
Always check routinely for a few days after installation to ensure the install is correct and fully sealed.
11. Light(s) correctly bonded and vessel bonding system check carried out (refer to relevant schematic and test procedures).
12. Test installation BEFORE entering water. Never connect/ disconnect lights whilst powered ON.
Never leave lights ON out of water for longer than 5 minutes followed by an off period of 1 hour.
13. Troubleshooting if required - most issues can be resolved by following the guidelines.

2 Overview

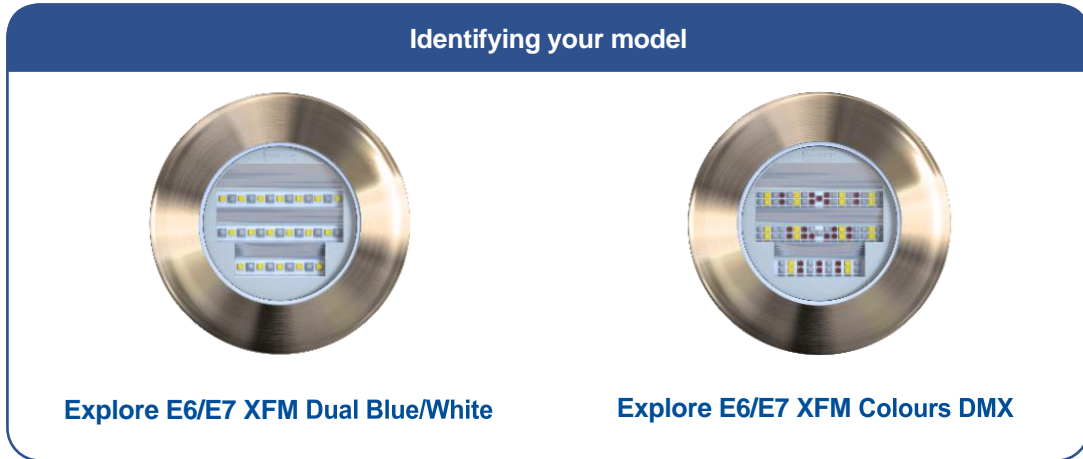

Product components breakdown

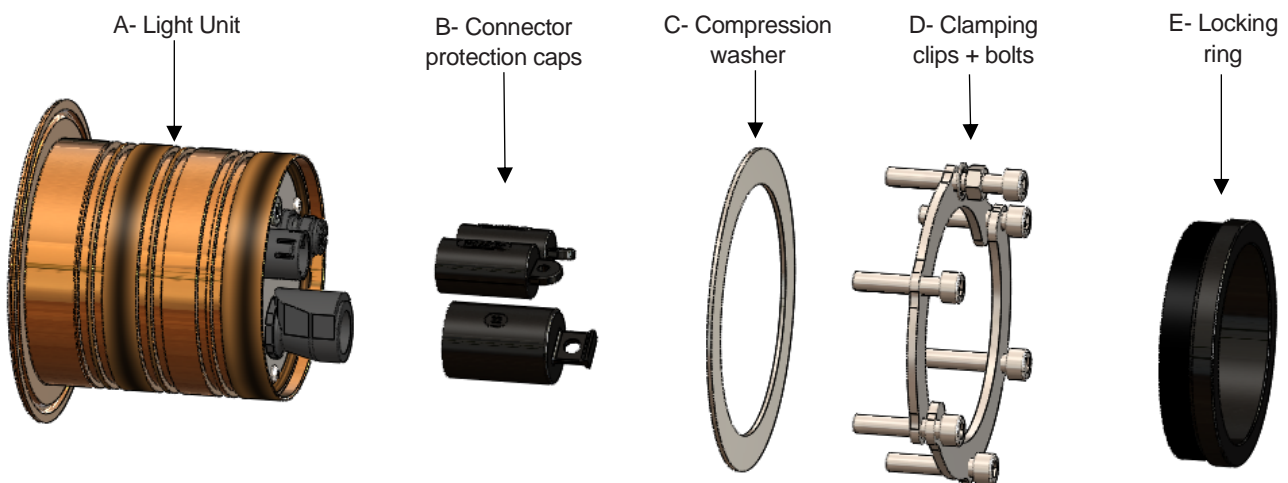

Power Source

Most installations will utilize on-board 12/24V DC power supply from a marine battery in which case the Explore DC Power Kit should be purchased. If AC power is being used on the vessel, an Explore AC Power Kit must be purchased. Please check the Explore E6/E7 XFM Light Choice Diagram available in the Appendix (Section 7.3) to evaluate all the options currently offered by OceanLED.

Use the chart below to determine the power supply requirements.

Power Consumption and Recommended Fuse Values

Model	Current @ 12V DC	Current @ 24V DC	Max Nominal Power consumption	Minimum PSU Power (15% reserve)	Recommended fuse 12V/24V DC
E6/E7 XFM Dual White/Blue	7.8 A	4.7 A	113W	130W	10 A
E6/E7 XFM Colour DMX	6.8 A	3.2 A	82W	94W	10 A

3 Preparing the Hull

 When installing an Explore unit, please ensure there is enough space on the inside of the vessel to remove the insert for maintenance/after sales services. For example, the XFM unit requires an additional 100mm / 4” from the rear of the mounting tube to allow the insert to be removed. (See overall dimensions below).

Ensure that the part of the light inside the vessel has a diameter of 100mm / 4” around it free from any insulation material.

OceanLED recommends using a qualified installer / technician when making modifications to your vessel. Please also consult the manufacturer for more detail on modifications and installation.

If lights are to be fitted to a conductive or wooden hull, an Isolation Kit must be used. Contact OceanLED for additional details.

<p>DELTRIN ISOLATION KIT</p> <p>Isolation of the metal parts of the Explore XFM Series Light from conductive or wooden hulls to prevent galvanic corrosion issues. The isolation kit is easily fitted to the rear of the light fixture using a suitable adhesive.</p> <p>PART NUMBER</p> <p>001-500638 - 80mm Delrin Isolation Sleeve Kit</p>	
---	--

Depth/Spacing

Ideally mount your lights at similar depth levels to ensure matching colour consistency through the water. Deeper lights will look duller and possibly differ in colour compared to shallower mounted units.

Spacing / Install Depth	E6/E7 XFM
Recommended Spacing	2.5-3m (8-10')
Recommended Installation depth (From the light waterline)	300mm (12")

Hull Thickness

Maximum hull thickness:

- Standard - 55mm (2.16")
- With Extension Kit - 119mm (4.7")

Hole Cut Out

Hole Cut out size - 83mm (3.27") / With Isolation Kit 89mm (3.5")

Overall Dimensions

See overall dimension schematic – See Appendix (Section 7.1)

4 Installation

4.1 INSTALLING THE LIGHT FIXTURE (HULL THICKNESS UP TO 55MM)

Explore E6/E7 XFM

Kit Includes



Explore E6/E7 XFM Light



Clamping Kit



Removal Tool

Additional items required not supplied by OceanLED:

- Marine sealant - 3M 4200 or equivalent
- Cable ties
- Waterproof Cable Connectors / Junction Box* (optional)
- Allen key (5mm)
- Thread lock - Loctite 243 or equivalent.

*Optional 4-Way Junction box available from OceanLED. Please contact OceanLED or your representative for further information.

! **DO NOT remove** the light cartridge from the mounting tube during installation. The light cartridge **MUST** stay fitted inside the mounting tube throughout the installation process to avoid the introduction of potential contaminants that may damage the product. The light cartridge can only be removed for maintenance or after sales purposes and OceanLED must be contacted prior to any light cartridge being removed from the mounting tube.

🔧 OceanLED recommends dry fitting all products. When installing, be sure that the light fits the area and secures to the hull using the appropriate hardware before applying any sealant.

🔧 When applying sealant to the light fixture, use OceanLED packaging material such as the light cardboard box when placing the light on the ground face down to prevent lens damage.

Installation Overview

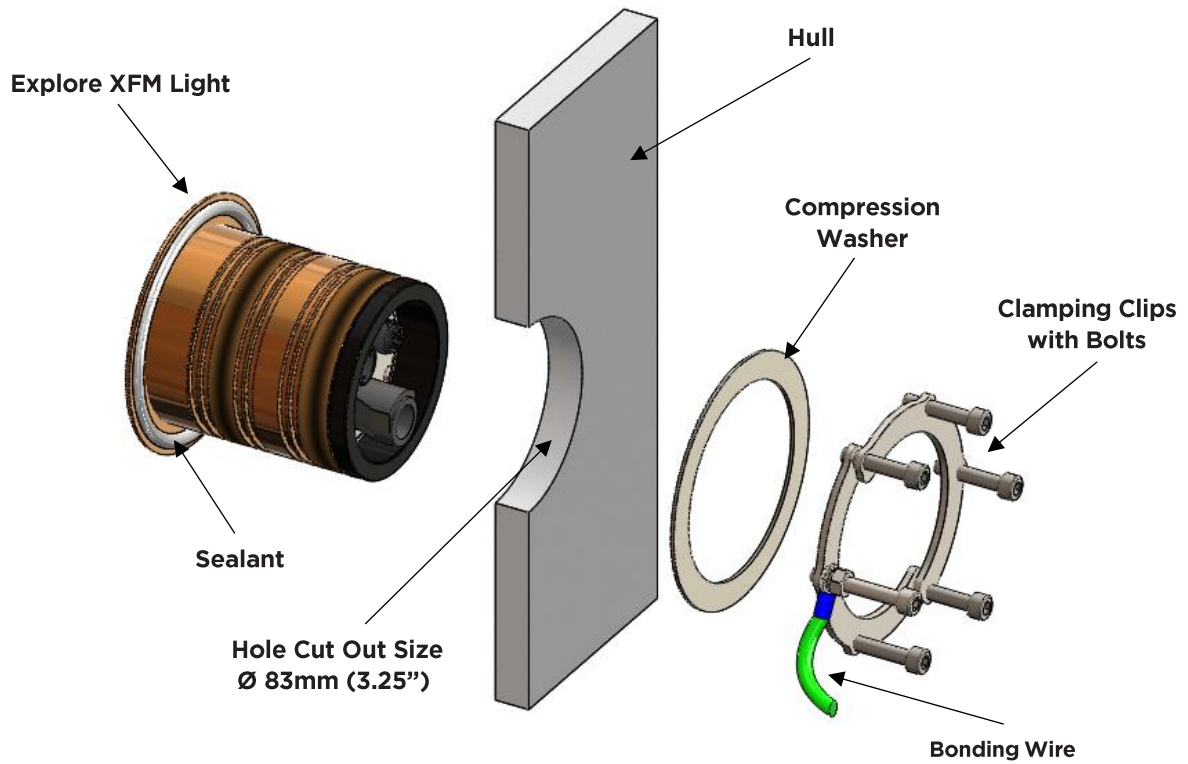

Exploded view of the assembly

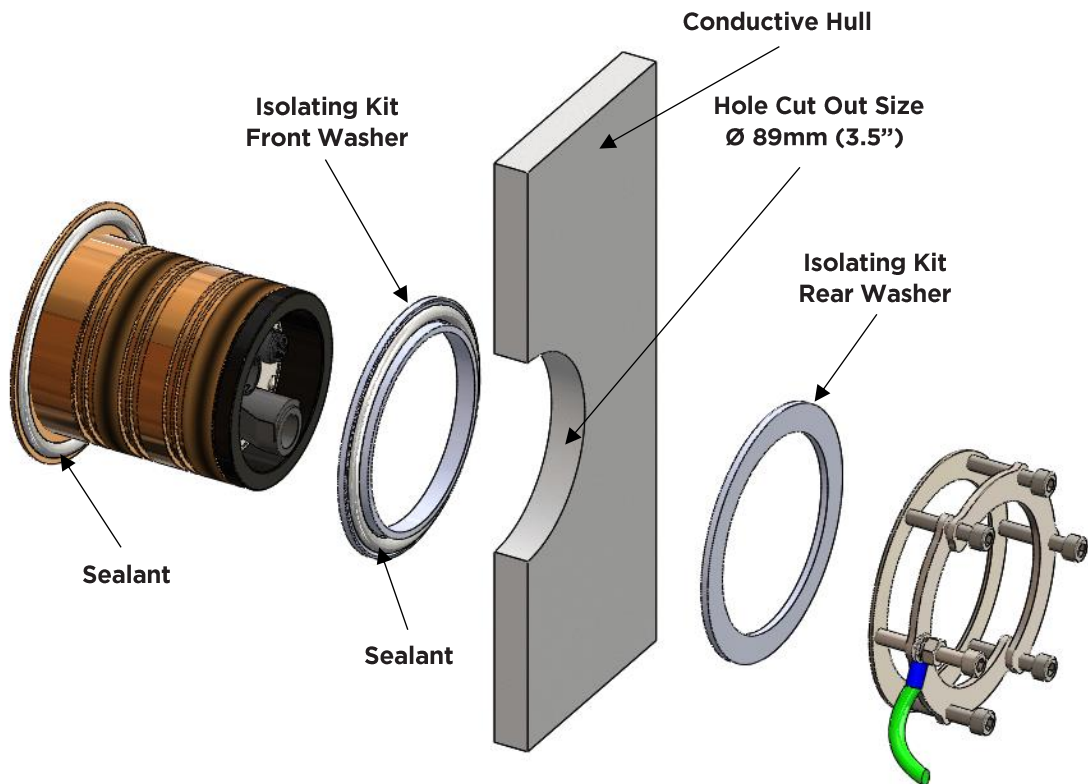

Exploded view of the assembly with the Delrin Isolation Kit

Installation (Once hull preparation is complete)

1. Test light(s) before fitting.
2. If using a Delrin Isolation Kit, insert the Isolation Kit front washer into the drilled hole and apply marine sealant to seal between the Front Washer and the hull.
3. Apply sealant to the rear of the mounting tube assembly's bezel to ensure a complete unbroken seal around the light.



Make sure sealant fills in the recess groove on the reverse of the light bezel:

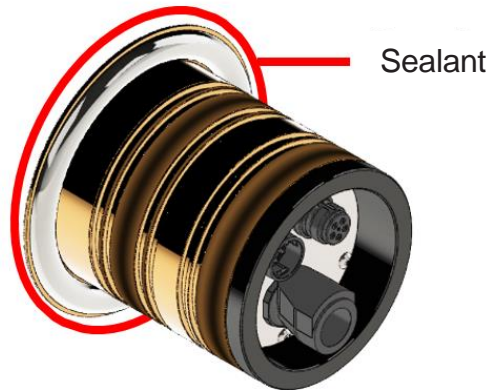

4. For the E6 model, to guarantee correct light orientation ensure the OceanLED logo on the reflector is located at the top before inserting it in the hull. If seen from the inside of the hull, the rear LED Indicator needs to be located at the top of the light (see image below).

For E7 fitment, ensure the light angle is correct for the location before fitting the light. If available, follow the OceanLED Light Placement Chart (LPC) where the required angle for each light position around the hull will be detailed.

On the E7, the LED Indicator is also used as a reference point for beam direction as well as orientation. For example, if viewed from the rear with the LED Indicator at the top, the beam will be pointing upwards. The OceanLED logo on the reflector also indicates the direction of the beam – see below. For further details, see the diagram in the Appendix (Section 7.6)



5. Insert the complete light unit (mounting tube assembly + light cartridge) into the hull, pressing the light hard into the hull and twist slightly to spread the sealant behind the light to ensure good adhesion.



 This process is made much easier if a second person is inside the hull to receive the light and install the locking equipment whilst supporting the light from the outside. Breakages due to lights falling out of the hull are NOT covered under warranty and can cause serious bodily injury as can any falling object.

6. If using a Delrin Isolation Kit, insert the Isolation Kit flat washer over the mounting tube and locate it flush with the hull.
7. Insert the stainless-steel compression washer over the mounting tube.

 The stainless-steel compression washer does not need to be flat to the hull, a slightly uneven surface can be compensated by the washer.

8. Place the two clamping clips together to form a circle, ensuring you pair 1 threaded and 1 non-threaded hole together. Fix the clips together using one of the screws provided so that the clips are located approximately halfway down the length of the screw. Locate the clips into the appropriate grooves (depending on hull thickness) on outside of the mounting tube so that the end of the screw is close to the washer. Fit the screws provided into the remaining holes, fixing the two clips together. Leave the longer screw out to connect the light to the vessel's cathodic protection system. Once connected, screw down this screw to the same position as the others (see step 10)



9. Tighten the locking screws using a 5mm Allen key, applying thread lock at point of thread contact with locking ring. Torque to 2Nm. **DO NOT** over-tighten locking screws, as you could damage the mounting tube, and this will not be covered under warranty.

Once you are satisfied that the unit is fully tightened, you will notice that sealant has squeezed out from around the perimeter of the light. Using a thinner or cleaner, apply to cloth and wipe off excess sealant to leave a clean seal. **AVOID CONTACT WITH LENS.** If you do not see sealant squeeze out from the body, you have not used enough sealant or tightened the unit enough to the hull. Carefully examine the installation to make sure the sealant you have installed on the unit is fully watertight. If in doubt, remove light, re-apply sealant and re-install.

10. Connect the bonding cable to the remaining screw and lock in place with the nut and shake proof washer provided. Tighten the locking screw using a 5mm Allen key, applying thread lock at point of thread contact with locking ring.

BONDING: The light **MUST** be attached to the vessels bonding / cathodic protection system. Once fitted it is mandatory to check that there is full continuity between the vessels cathodic protection system and the outer bezel of the mounting tube assembly. Please see the bonding check schematic in the Appendix (Section 7.2).

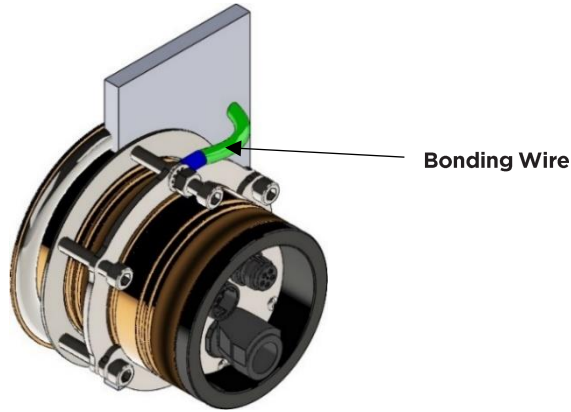

4.2 INSTALLING THE LIGHT FIXTURE (HULL THICKNESS ABOVE 55MM)

Extension Kit

Kit Includes



Mounting Tube



Compression Tube

Additional items required not supplied by OceanLED:

- Thread lock - Loctite 243 or equivalent.

Assemble the mounting tube extension on the back of the standard light mounting tube then follow the procedure above in section 4.1:

1. Remove the locking ring from the mounting tube.

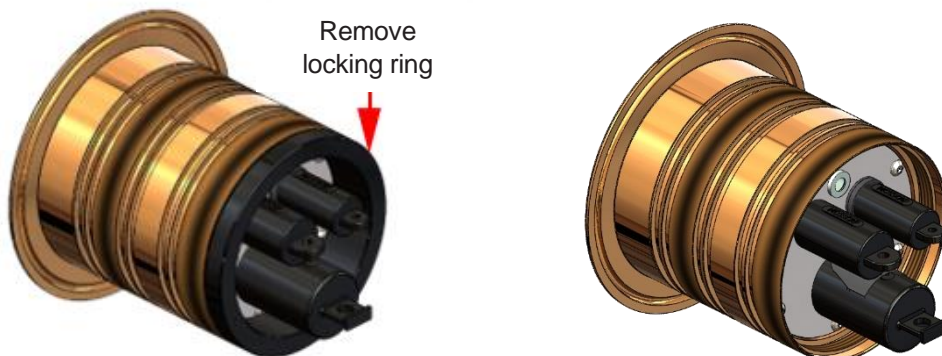

2. Apply thread lock (Loctite 243 or equivalent) on the thread of the additional mounting tube then screw it all the way down onto the back of the mounting tube.

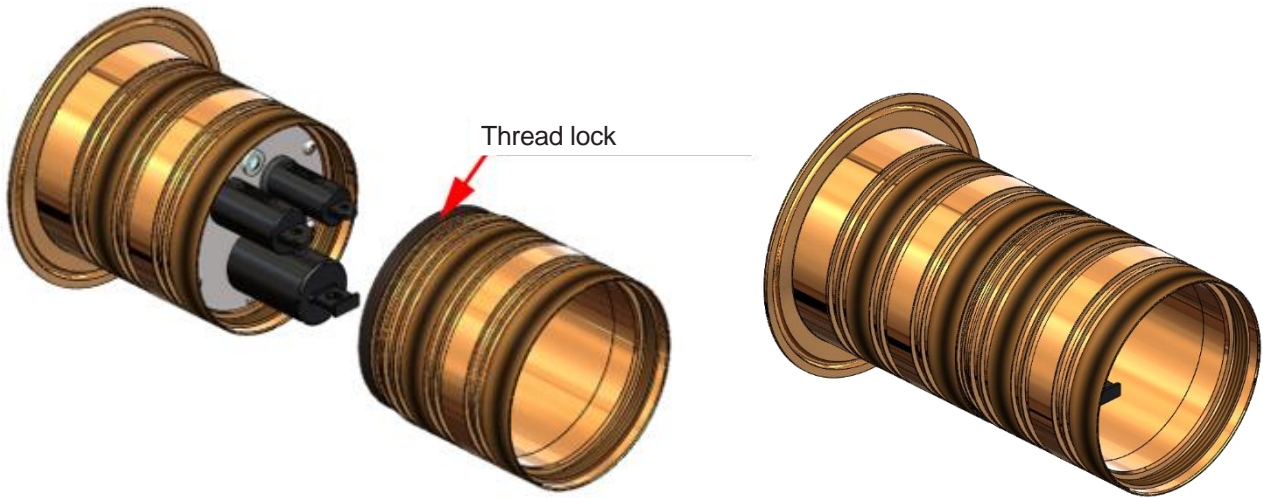

3. Fit the compression tube inside the mounting tube extension and slide it all the way down into the tube until it reaches the light cartridge.



4. Screw the locking ring back onto the mounting tube extension until tight. **Now follow the steps in section 4.1.**



4.3 INSTALLATION OF OPTIONAL REAR ENCLOSURE

OceanLED Explore Series XFM Rear Enclosure for installations that require increased protection from temporary submersion inside the hull. The Enclosure can be retrofitted to existing Explore XFM installations, as well as new installs. Refer to the installation manual supplied with the rear enclosure for detailed installation instructions.

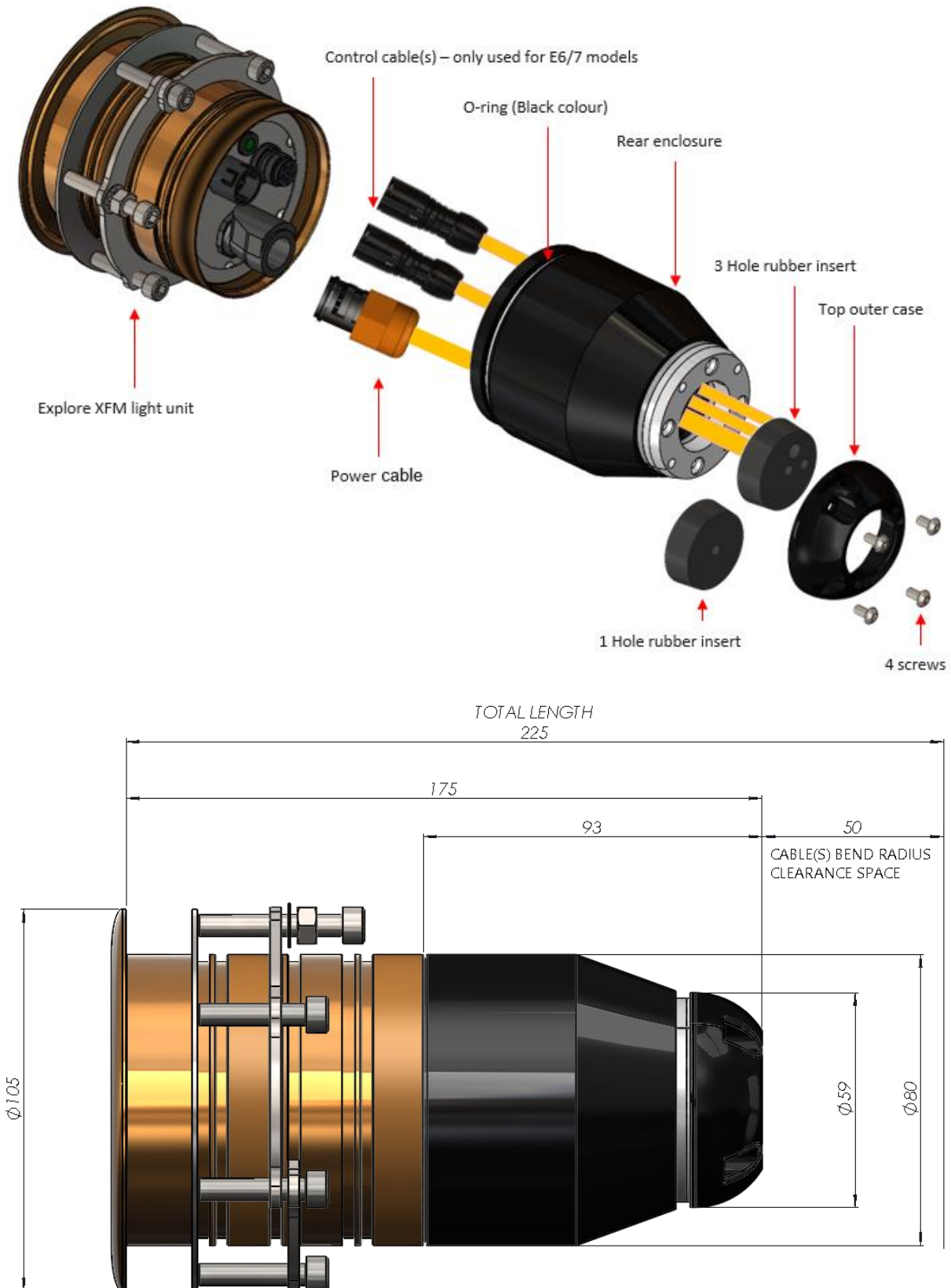

4.4 INSTALLATION OF EXPLORE AC POWER KIT

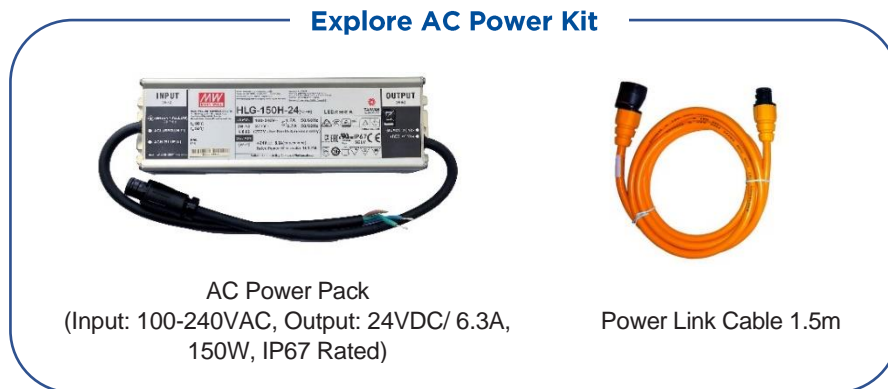

Additional items required not supplied by OceanLED:

- Screws to secure the Explore AC Power Pack
- Junction box / waterproof connectors
- Sufficient cable to connect the Explore AC Power Pack
- Suitable fuse / breaker(s)

! Always consult a qualified electrician when connecting OceanLED light fixtures.

Never use power tools to secure the Explore AC Power Pack: hand tighten only.

When connecting light units, please note that all OceanLED lights will operate within a specific voltage range. Please check the electrical information to ensure cable gauge, fuse and breakers size follow the recommendations.

Always mount the Explore AC Power Pack in a dry location, it should not sit in standing water at any time.

! The 3-core input is for power (Brown=Live; Blue=Neutral; Green/Yellow=Earth) and the two pin Deutsch Connector is for the light.

1. Depending on the model and number of lights installed, you will need to pull the correct sized power cable from the AC Power (breaker/fuse panel) to the Explore AC Power Pack locations. Ensure the correct sized tinned marine grade cable is used to avoid voltage drop issues.
2. Fix Explore AC Power Pack into required position. Ensure chosen Explore AC Power Pack location is near enough to connect light cable without applying undue stress.

! Never leave the bare cables unprotected. Take care to not leave the bare wire ends in bilge water before making the waterproof connections. Water deposits in the connectors and cables will cause corrosion. Over time water can also work its way into the unit along the inside of the cable due to capillary action causing the light to fail. This will NOT be covered under warranty.

3. Connect the Explore AC Power Pack to the AC Power. Ensure the size fuse/breaker, cable and connector have the correct specification and are watertight. Make sure any heatshrink used completely encapsulates the outer wire sheath (the use of glue-lined heatshrink is highly recommended to ensure water tightness).

! Corrosion of wire and/or water ingress into the light unit via cable is NOT covered under warranty.

4. Connect the Deutsch connector from the Power Pack to the light using the Power Link Cable.
5. Secure cables ensuring where the cable exits the light it is not under undue stress. Finish and test the light units **BEFORE** the vessel goes into the water.

Example of the AC Installation (with the AC Power Kit)

Explore XFM Lighting System Control Options

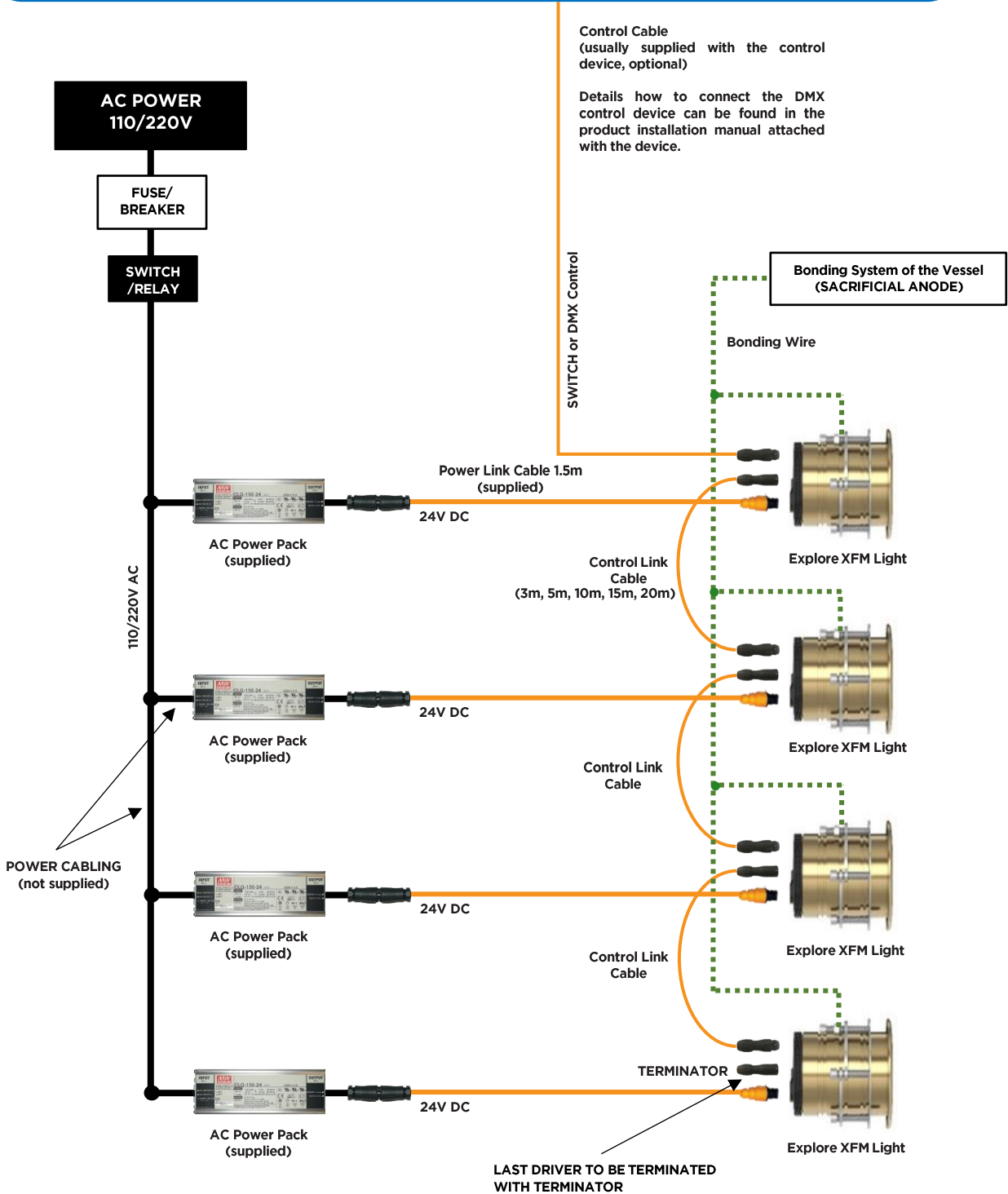
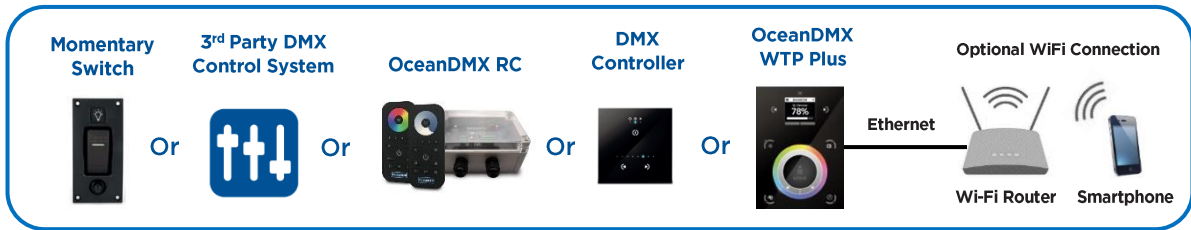

4.5 INSTALLATION OF EXPLORE DC POWER KIT



Additional items required not supplied by OceanLED:

- Screws to secure the DC Driver
- Waterproof connectors/ Junction Box* (optional)
- Sufficient cable to run connections to power source.
- Suitable fuse / breaker(s)

*Optional 4-Way Junction box available from OceanLED. Please contact OceanLED or your representative for further information.



Always consult a qualified electrician when connecting OceanLED light fixtures.

When connecting light units, please note that all OceanLED lights will operate within a specific voltage range. Please check the electrical information to ensure cable gauge follow the recommendations.

Never leave the bare cables unprotected. Take care to not leave the bare wire ends in bilge water before making the waterproof connections. Water deposits in the connectors and cables will cause corrosion. Over time water can also work its way into the unit along the inside of the cable due to capillary action causing the light to fail. This will NOT be covered under warranty.



For complete instructions on DC connections, please refer to ABYC codes of practice and other applicable codes and ordinances for DC connections.

Where multiple lights are fitted, and especially on 12V systems, it is advised to use a relay system to supply the switched power to the lights, to reduce load on the switch and voltage drops caused by long cable runs to the switch location.

1. Depending on the model and number of lights installed, you will need to pull the correct sized power cable from the DC power source (breaker/fuse panel) to the light locations to supply constant power to the light units. It is imperative that the correct sized tinned marine grade cable is used to avoid voltage drop issues. Use the tables in the Appendix (Section 7.4 & 7.5) as a guide to the required cable gauge.
2. It is imperative that either the OceanLED supplied fuse is fitted to the power circuit of each light or a suitable protection device is used to protect the cable/light unit. It is important to also ensure the polarity is correct. Failure to do so will void the warranty of the unit. It is recommended to use our 4-way fused junction box. See the table in Section 2 for power consumption and recommended fuse values.
3. Using waterproof butt splices or IP66 waterproof junction boxes, make the connections at either end of the system to attach the lights to the DC system. (Red wire = +12/24V DC, Black wire = GND). Make sure any heatshrink used completely encapsulates the outer wire sheath (the use of glue-lined heatshrink is highly recommended to ensure water tightness).
4. Secure cables ensuring where the cable exits the light it is not under undue stress. Finish and test the light units **BEFORE** the vessel goes into the water. Never install a new light fixture then leave the vessel in the water unchecked for several days.

Example of the DC Installation (with DC Power Kit)

Explore XFM Lighting System Control Options

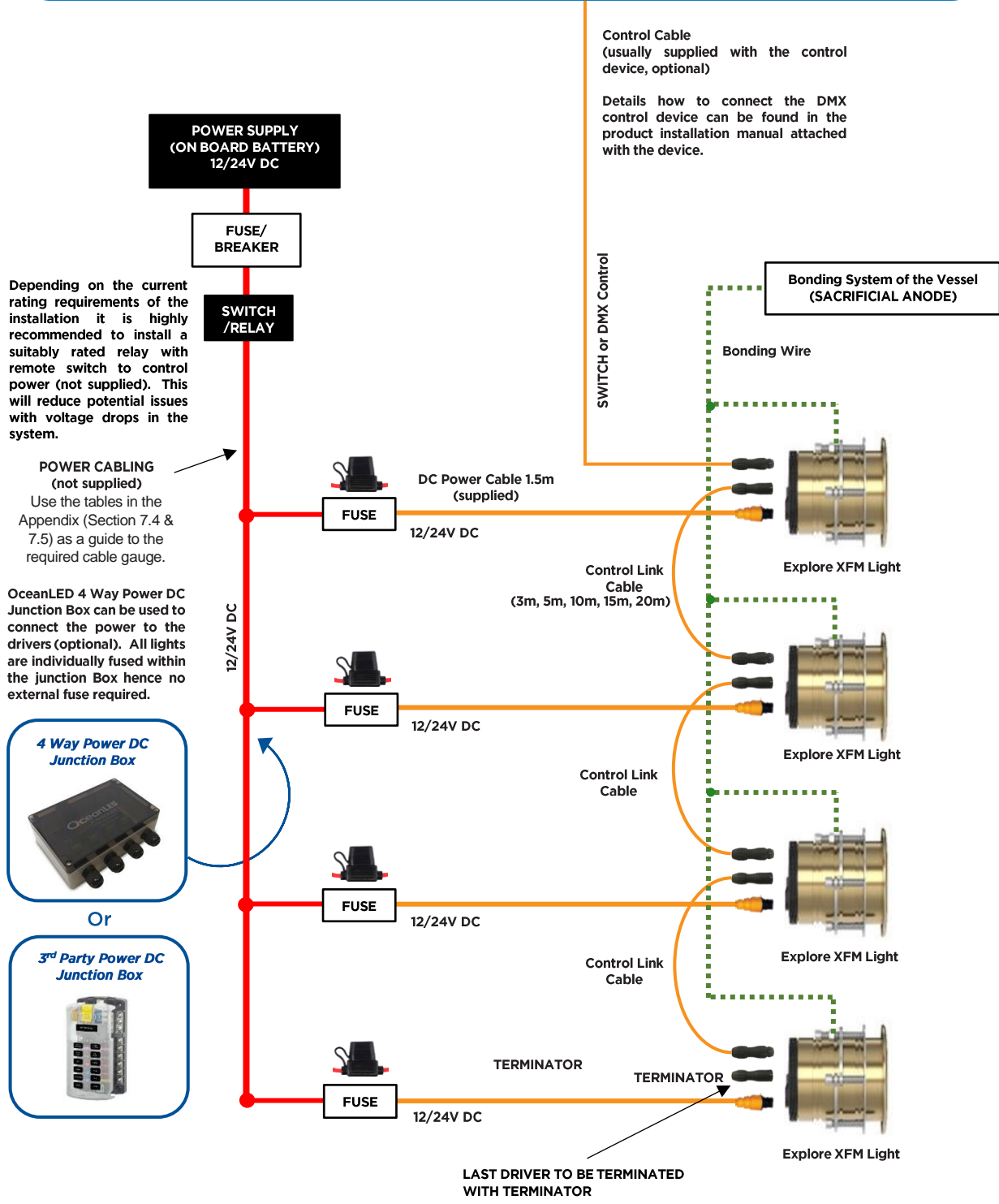
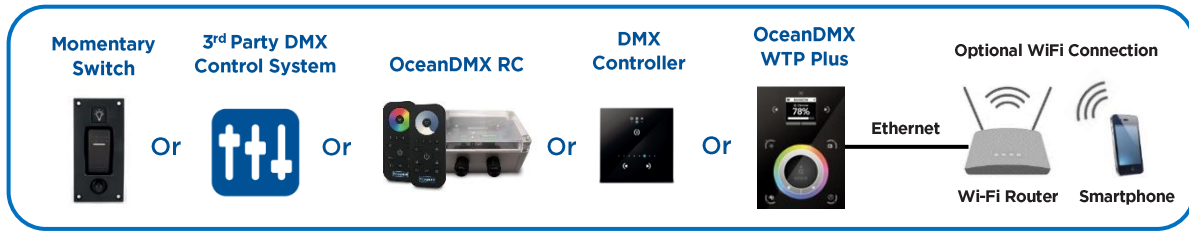

4.6 CONTROL SYSTEM INSTALLATION

Switch Control

Additional items required not supplied by OceanLED:

- Push switch (Normally open, momentary type).



To use Switch Control, the Explore Control Input Cable and Terminator Kit is required.

To connect the lights to enable control of all lights using a single switch, Explore E6 & E7 Control Link Cables must be used. The quantity of Control Link Cables required per installation is equal to the number of lights minus 1 (Example: If 10 lights are used, 9 control link cables are required). Please consult the Explore E7 Light Choice Diagram in the Appendix (Section 7) for details.



Ensure power is disconnected before attempting to connect or solder any wire.

1. Connect one contact of the switch to the red wire of the Explore Input Control Cable. Connect the black (Ground), yellow (DMX +) and brown (DMX -) wires together and connect to the other contact of the switch:

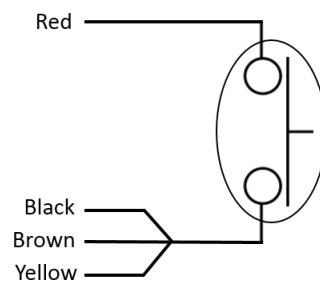

2. Plug the Switch cable to the 'Control In' Connector of the first light.
3. Using the Control Link Cable, connect the 'Control Out' of the first light to 'Control In' of the next light. Repeat until all the lights are connected. Check the diagram below for clarification.
4. Plug the Explore Terminator to the 'Control Out' of the last light.

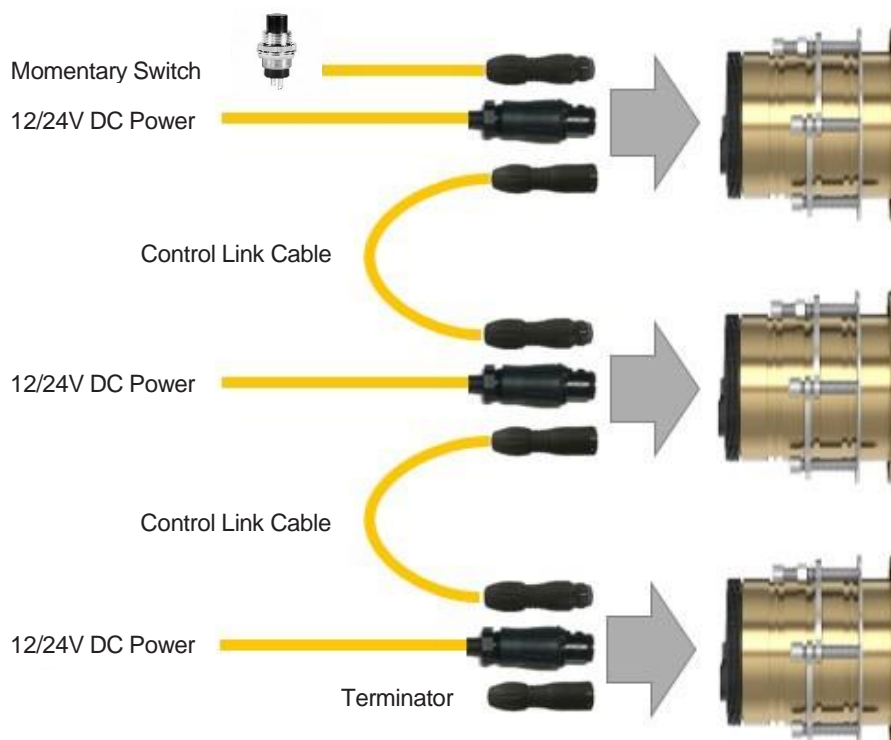

OceanLED DMX Control Kits



To use OceanLED DMX Control, one of our DMX kits must be purchased from OceanLED. Please consult the Explore E6/E7 XFM Light Choice Diagram for details.

To enable the DMX Control of all lights, Explore E6 & E7 Control Link Cables must be used. The quantity of Control Link Cables required per installation is equal to the number of lights minus 1 (Example: If 10 lights are used, 9 control link cables are required).



Ensure power is disconnected before attempting to connect or solder any wire.

Please consult the manual for the purchased DMX Control Kit for more information on installation and operation.

3rd Party DMX Control

Additional items required not supplied by OceanLED:

- External DMX Control System



To use a 3rd Party DMX Control, the Explore Control Input Cable and Terminator Kit is required.

To enable the DMX Control of all lights, Explore E6 & E7 Control Link Cables must be used. The quantity of Control Link Cables required per installation is equal to the number of lights minus 1 (Example: If 10 lights are used, 9 control link cables are required).



Ensure power is disconnected before attempting to connect or solder any wire.

1. Connect the DMX Control unit to the Explore Control Input Cable following the wiring connections below:

Cable colour	Signal
Black	GND
Yellow	DMX +
Brown	DMX -
Red	Not used

2. Plug the Explore Control Input Cable to the 'Control In' Connector of the first light.
3. Using the Control Link Cable, connect the 'Control Out' of the first light to 'Control In' of the next light. Repeat until all the lights are connected. Check the diagram below for clarification.
4. Plug the Terminator into the 'Control Out' of the last light.

DMX Addressing

- OceanLED Explore E6/E7 XFM lights use DMX-512 standard for communication.
- As default the base address of the lights is set to DMX address 1.
The default base address of the lights can be changed if required. This can either be done using a third party RDM (Remote Device Management) controller, or by using the OceanLED Explore Configuration Tool
- Dual colour lights use two DMX addresses, the first for the Blue channel, the second for the White channel.
- Colours lights use four DMX channels – the first for the Red channel, second for the Green Channel, third for the Blue channel, and the fourth for the White channel.



The DMX standard recommends a maximum of 32 devices to be connected in one chain, and a maximum network length of 300m. If installation requires more lights than this, or a longer network length then please contact OceanLED for advice.

--- Third Party RDM controller ---

Third Party RDM (Remote Device Management) software/ controller permits a controlling device to discover and then configure, monitor, and manage lighting devices connected through a DMX512 network.



To use a 3rd Party RDM Controller, the Explore Control Input Cable and Terminator Kit is required Please contact your OceanLED representative for more information.

Additional items required not supplied by OceanLED:

- Third party RDM-DMX512 Controller
- Third party RDM Software Manager

--- OceanLED Explore Configuration Tool ---

The Explore Configuration Tool is a USB interface to allow remote configuration of the Explore E6 & E7 lights using a Windows PC. It allows the setting of base DMX address, change of operating modes and readback of stored parameters.

Communication with the lights is achieved using the Remote Device Management (RDM) protocol over the existing DMX network.



Explore Configuration Tool kit can be purchased from OceanLED. Please contact your OceanLED representative for more information. The kit comes with detailed installation manual.

General info:

Items required:

- PC/Laptop (Win7,8,10 only) with free USB 2.0 port and with config app installed
- Control cable
- Explore-Series Lights

4.7 FINALISING THE INSTALLATION

The Explore XFM mounting tube is constructed from corrosion resistant Aluminium Bronze and does not require further protection. The glass is pre-coated with a specialized Tritonium® coating which makes the surface of the glass lens a non-stick layer.

OceanLED does not recommend that bottom paint or any type of anti-fouling agent is applied to the glass and/or bezel, as damage may occur due to chemical incompatibility. If bottom painting of the bezel is deemed essential, then an area of at least 5mm should be left uncoated around the glass lens:

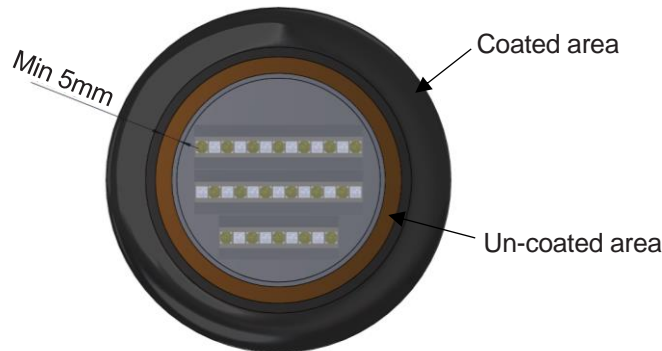

The protective lens sticker should be removed once all work on the vessel is complete.

4.8 TEST YOUR INSTALLATION

Always test the lights **BEFORE** the vessel goes back into the water. At this final stage make sure all of the system is operational. If you have any issues, please contact your local OceanLED representative.

 **Never install a new light fixture then leave the vessel in the water unchecked for several days.**

When the vessel is placed in the water, immediately check for leaks. Note that very small leaks may not be readily observed. It is best not to leave the vessel in the water for more than 3 hours before checking it again. If there is a small leak, there may be considerable bilge water accumulation after 24 hours. If a leak is observed, you must **TAKE ACTION IMMEDIATELY** to prevent damage.

5 Operation / Maintenance

5.1 OPERATION

Switch Control

The Switch Control mode allows the user to switch between colours and strobe modes using a push switch.

The sequence for the Explore E6/E7 XFM Dual White/Blue is a closed loop as follows:

1. Solid White (*default stage after power cycling*)
2. Solid Blue
3. Fade White / Blue
4. Strobe Blue
5. Strobe White
6. Strobe White / Blue
7. 50% White and 50% Blue

After step 7 the next button press will reset the sequence back to step 1.

The sequence for the Explore E6/E7 XFM Colours DMX is a closed loop as follows:

1. Solid Chosen Colour (*default stage after power cycling – last chosen colour stored*)
2. Strobe Chosen Colour
3. Colour Cycle

If during the colour cycle (step 3), the switch is pressed again, the cycle will stop and the current colour will be stored and remain static (i.e., go back to step 1 in the sequence, with a new stored chosen colour).

DMX Control

Please refer to the purchased DMX Controller for details about how to use it. For 3rd party DMX control see section 4.5.

5.2 MAINTENANCE

Marine growth can build up quickly on the light and can reduce the performance in just a few weeks.

To help prevent this, all OceanLED lights have been coated with a specialized Tritonium® coating which makes the surface of the glass lens a non-stick layer. Lights should be cleaned with a boat brush or similar biweekly, or as needed to keep the lens of the light clean.

Growth varies greatly around the world and maintenance is imperative to the proper operation and longevity of the product. If heavy fouling occurs, barnacles can be removed from the lens using a plastic scraper and moderate pressure under water. If cleaning the lens while the boat is out of the water, wet the lens before scraping. Never scrape or try to remove barnacles from a dry lens.

 **Never use high pressure jet wash to clean the lens / bezel as this will damage the seals and void the warranty.**

5.3 REPLACEMENT PARTS

The light source of this luminaire (light cartridge) shall only be replaced by the manufacturer or his service agent or a similar qualified person.

If the external flexible cable of this unit is damaged, contact your local OceanLED representative to arrange for replacement (cable must only be replaced by OceanLED, service agent or a similar qualified person).

Lost, broken and worn parts can be replaced on request and can be obtained through your local OceanLED representative.

5.4 LIGHT CARTRIDGE REMOVAL – SINGLE MOUNTING TUBE

! Before proceeding with this operation, you **MUST** seek permission from either the manufacturer or your OceanLED representative.

DO NOT remove the light cartridge from the mounting tube during installation. The light cartridge **MUST** stay fitted inside the mounting tube throughout the installation process to avoid the introduction of potential contaminants that may damage the product.

Additional Tools required not supplied by OceanLED

- Allen key (2mm).
1. If the vessel is in water, check that the front glass is present and intact. Never remove a cartridge with the vessel in water if damage to the glass lens is suspected.
 2. Turn power off and unplug all the connectors on the back of light.
 3. Remove the locking ring from the mounting tube.
 4. Undo one of the six screws from the back of the light cartridge to allow the Explore Removal Tool to be placed (see image below).

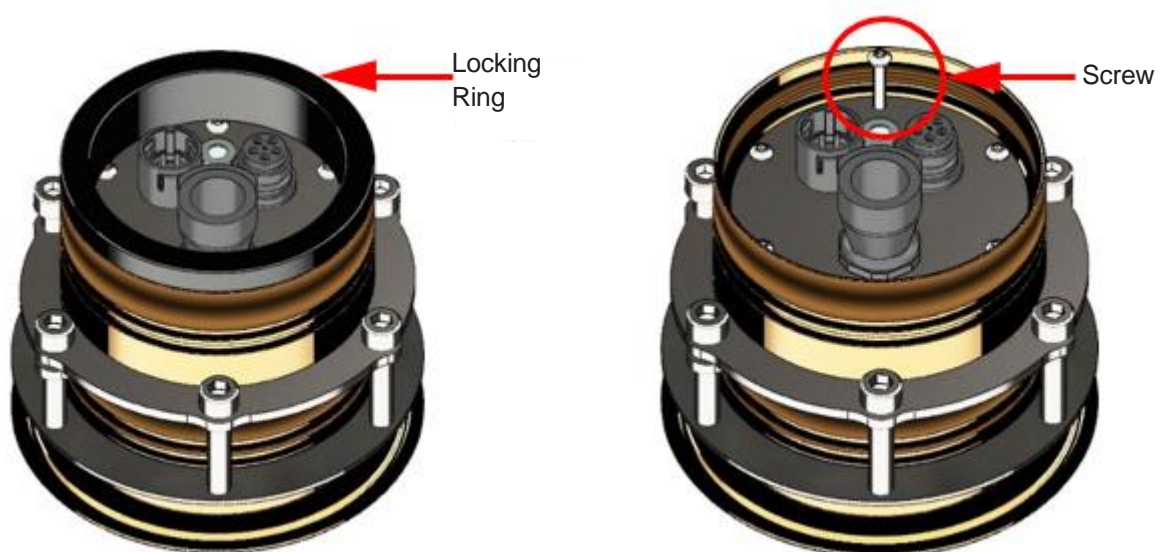

To ease the removal process, another screw can be removed to act as a breather.

5. Place the Explore Removal Tool under the head of the undone screw making sure that the screw engages with the slot on the tool, then fasten the screw in a clockwise motion. By tightening down the screw the light cartridge will be pulled out of the mounting tube.

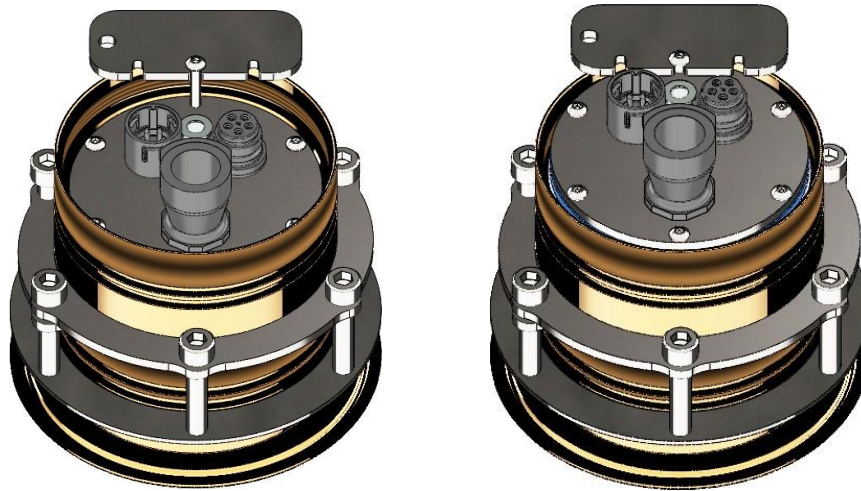

6. Finish pulling the light cartridge out by hand with the help of the tool to fully remove it from the mounting tube.

5.5 LIGHT CARTRIDGE REMOVAL – EXTENDED MOUNTING TUBE

! Before proceeding with this operation, you **MUST** seek permission from either OceanLED or your OceanLED representative.

DO NOT remove the light cartridge from the mounting tube during installation. The light cartridge **MUST** stay fitted inside the mounting tube throughout the installation process to avoid the introduction of potential contaminants that may damage the product.

Additional Tools required not supplied by OceanLED:

- T-Handle Allen key (2mm) 80mm length.
1. If the vessel is in water, check that the front glass is present and intact. Never remove a cartridge with the vessel in water if damage to the glass lens is suspected.
 2. Turn power off and unplug all the connectors on the back of light.
 3. Remove the locking ring and the compression tube from the mounting tube.
 4. Undo and remove one of the six screws from the back of the light cartridge to ease removal.
 5. Loosen the other 5 screws by the same height (approx. 15-20 full rotations of the Allen key) without removing them.
 6. Insert the Explore Extended Removal Tool into the mounting tube ensuring the cut-outs in the tool align with the screws. Twist the tool to align.

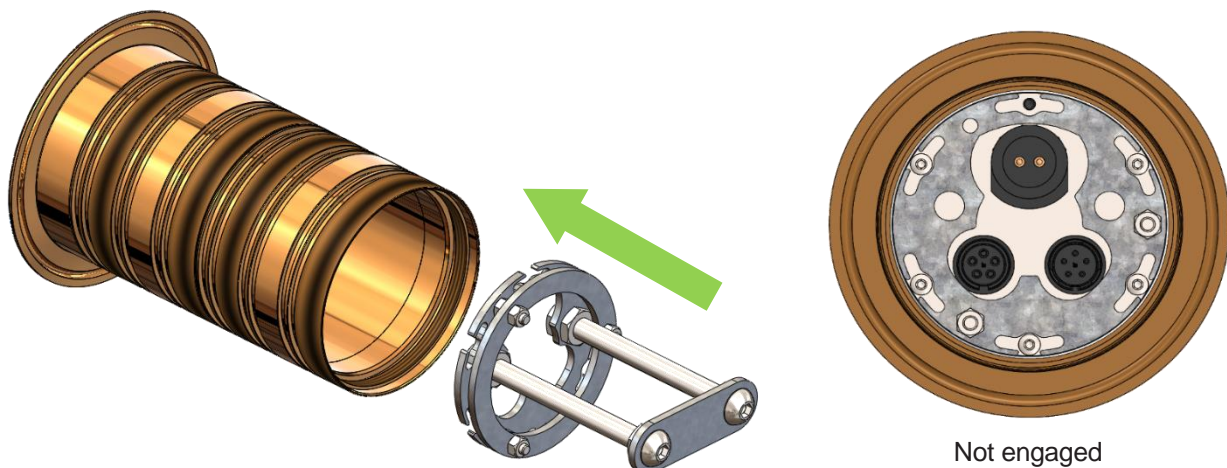

- Twist the tool to engage the screw heads. Once the screw heads are engaged twist and pull the tool outwards to extract the light.

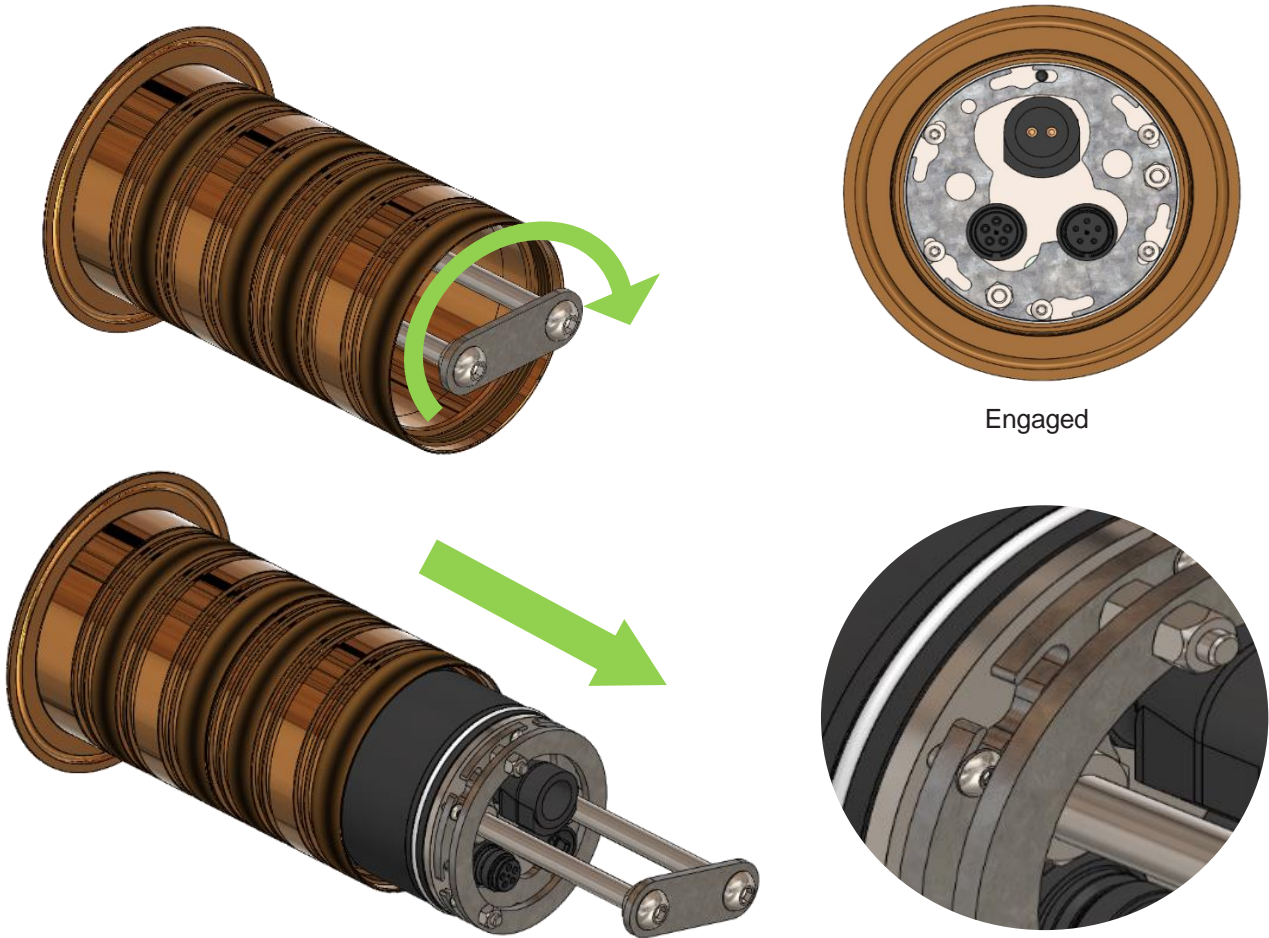

5.6 LIGHT CARTRIDGE INSTALLATION

Additional Tools required not supplied by OceanLED:

- Allen Key (2mm)

 **Before installing the light cartridge, clean the inside of the mounting tube with isopropyl alcohol cleaner and let it dry. Failure to do this may introduce potential contaminants that may damage the product.**

Lubricant substances of any kind MUST NEVER be used to ease the insertion of the light cartridge into the mounting tube. Should any help to insert the light cartridge be needed OceanLED recommend the use of a small quantity of Isopropyl Alcohol sprayed onto the O-Ring on the back of the light cartridge.

- Inspect the mounting tube and light cartridge to ensure no contaminant (grease, debris, dirt), and/or water are present.
- Using the 2mm Allen key, remove one of the screws on the back of the light cartridge to act as a breather. Failure to do so will make the installation process significantly harder.
- Align the light cartridge with the mounting tube - ensure that the LED Indicator is at the top and central on the back of the light cartridge or aligned as per OceanLED custom alignment instructions.
- Push the light cartridge in slowly until it bottoms against the front bezel.

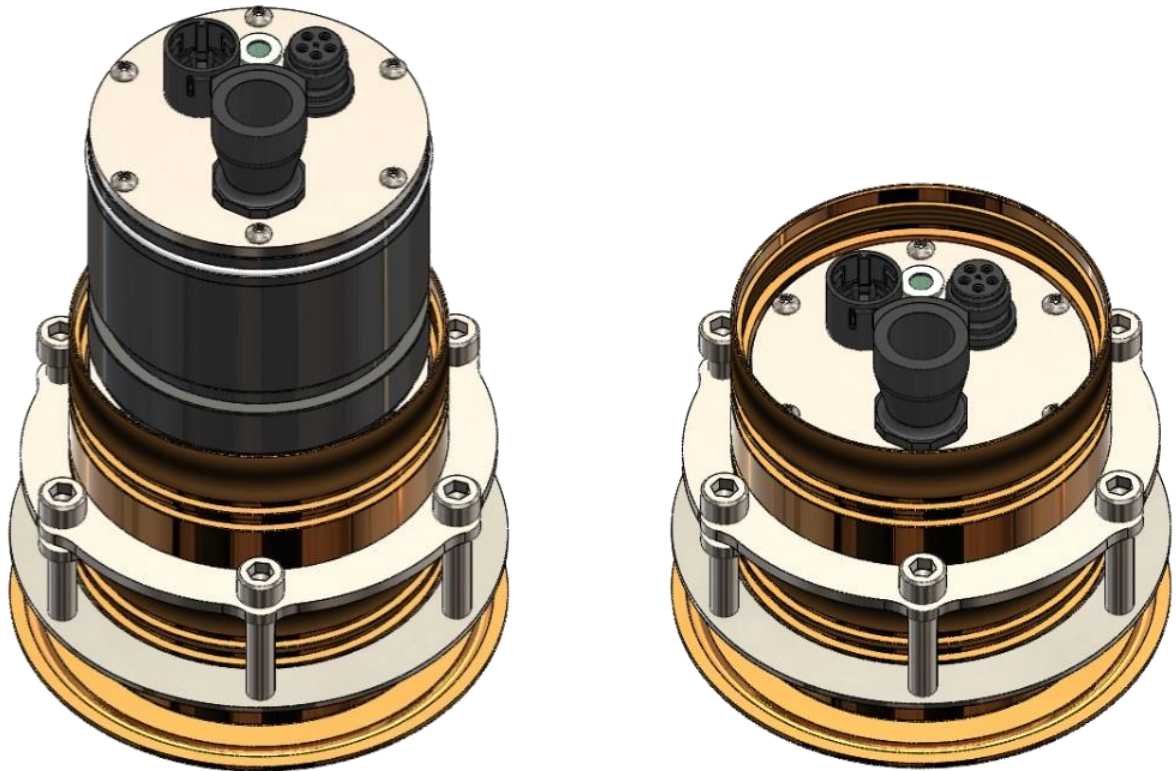

 **Make sure to align the light before fully inserting it to the mounting tube. Ensure that the LED Indicator is at the top and central on the back of the light cartridge or aligned as per OceanLED custom alignment instructions.**

5. Re-install the screw using a 2mm Allen key (hexagonal key). Re-install the locking screw making sure it is bottomed out against the light cartridge.
6. Connect the power cable and test the light.

6 Troubleshooting

6.1 TROUBLESHOOTING PROBLEMS AND THEIR SOLUTIONS

The Explore E6/E7 light have a built-in Rear Indicator LED that will confirm that the light is working inside the designed parameters and will give information if a fault has been detected.

The Rear Indicator should be lit when light is powered and on. When receiving a DMX signal, the Rear Indicator will turn on and off approximately once per second. If light is in Firmware/Bootloader update mode, the Rear Indicator LED will flash rapidly approximately 3 to 4 times per second.

Should any flashes be observed outside of the time frames mentioned above, please refer to the table below.

The table below summarizes the fault codes the Rear Indicator LED can show. The fault code is shown by a repeated cycle of a succession of flashes followed by an off period.

EXPLORE SERIES E6/E7 XFM				
NO' OF FLASHES	DESCRIPTION OF FAULT	CHECK	CAUSE	FIX
1	Driver board Temperature Sensor Failure	-	Light is faulty.	Contact your dealer.
2	LED board temperature sensor failure	-	Light is faulty.	Contact your dealer.
3	Power Issue – large Voltage drop on light power-up detected 10 times	Check wiring gauge. Check if power source can supply enough current.	Incorrect wiring. Inadequate power source.	Replace wiring with correct gauge. Replace power source.
4	Power supply Voltage too low	Check voltage supply to the light is between 11V and 32V DC (The light will still work between 10 and 11 volts however at reduced brightness)	Voltage is too low	Investigate reason for low voltage and fix
5	Power Supply Voltage too high	Check voltage supply to the light is between 11V and 32V DC	Voltage is too high	Investigate reason for high voltage and fix

If the light doesn't recognize the fault but the fault is still present, please check the tables on the following pages.

EXPLORE SERIES E6/E7 XFM			
PROBLEM	CHECK	CAUSE	FIX
Light does not look bright	Check that there is no marine growth on the lens	Marine growth	Clean the lens as per maintenance advice
	Check voltage supply to the light is between 11V and 32V DC (The light will still work between 10 and 11 volts however at reduced brightness)	Voltage is either too high or too low	Investigate reason for high or low voltage and fix
	Check voltage supply is stable and does not fluctuate	Voltage is fluctuating	Investigate reason for voltage fluctuation and fix
	Check that the electrical connections between the light and the supply cable have been made correctly and recommended cable gauge has been used	Poor electrical connection	Remake connection and seal joint correctly
	Confirm all LEDs are illuminated	1 or more LEDs are not working	Contact your dealer.
	Check lights to see if water is present inside the light	Water present	Contact your dealer.
	Check cable connections for corrosion	Corrosion is present	It is not advised to reuse the cable if water is present inside. Contact your dealer for a replacement. This is NOT covered by the warranty
Light has water inside	Check integrity of lens	Light will require replacing	This is not covered by the warranty - Contact your dealer for a replacement light. Only use genuine OceanLED parts
	Check connections to make sure they are not submerged in water	Light will require replacing	This is not covered by the warranty
	Check cable to make sure there is no damage to the cable	Cable will require replacing	This is not covered by the warranty. Only use genuine OceanLED parts
	Checked all factors that are above, and the light still does not work	Light faulty	Contact your dealer for a replacement light

EXPLORE SERIES E6/E7 XFM			
PROBLEM	CHECK	CAUSE	FIX
Light does not light up	Check that the electrical connections between the light and the supply cable have been made correctly	Poor electrical connection	Remake connection and seal joint correctly
	Check the cable gauge is sufficient for the current draw of the light	Cable gauge insufficient resulting in voltage drop	Increase cable gauge
	Check that the wiring polarity is correct, red to positive and black to negative	Polarity incorrect	Change the wiring polarity and seal joint correctly. Damage to light may have occurred.
	Check that there is power supply to the light cable connection	Poor electrical connection	Trace the cables back, checking at joints until break has been located. Then rectify the problem and seal joint correctly
	Check that the electrical connections between the supply cable and the light circuit breaker or fuse have been made correctly	Poor electrical connection	Remake connection and seal joint correctly
	Check that the in-line fuse is intact and not blown	Replace fuse	If fuse keeps blowing, then there is a short circuit in the light system that must be traced and rectified. If no external short can be located contact your dealer
	Exchange the power cable (between light and power supply) with one from a working light	Light works, faulty cable	Contact your dealer for a replacement cable
	Check that the light supply circuit breaker is closed, or the fuse has not blown	Close circuit breaker / replace fuse	If breaker / fuse keeps blowing, then there is a short circuit in the light system that must be traced and rectified. If no external short can be located contact your dealer

EXPLORE SERIES E6/E7 XFM													
PROBLEM	CHECK	CAUSE	FIX										
Light/s do not respond to DMX controller	Check that the DMX electrical connections between the DMX controller and the light unit have been made correctly (the green LED at the back of the light should be blinking when receiving the DMX signal)	Solid Green LED DMX not connected or poor electrical connection	Remake connection										
		No Green LED, faulty light unit	Contact your dealer										
	Check the link cable connection between the light units	Damaged link cable, damaged link cable plug	Contact your dealer										
	Ensure the terminator has been fitted in the DMX OUT of the last driver. (120 Ohm resistor between DMX+ and DMX-)	Terminator not fitted	Fit terminator										
	<p>Disconnect the control cable from the output of the controller and measure the resistance between the DMX+ (yellow wire) and DMX- (brown wire). This value should be greater than 120 Ohms but not exceed 180 Ohms.</p> <table border="1"> <thead> <tr> <th>Cable colour</th> <th>Signal</th> </tr> </thead> <tbody> <tr> <td>Black</td> <td>GND</td> </tr> <tr> <td>Yellow</td> <td>DMX +</td> </tr> <tr> <td>Brown</td> <td>DMX -</td> </tr> <tr> <td>Red</td> <td>Not used</td> </tr> </tbody> </table>	Cable colour	Signal	Black	GND	Yellow	DMX +	Brown	DMX -	Red	Not used	The measured value is not between 120-180 Ohms	Check that all light units are connected in chain and the last light has terminator fitted in
		Cable colour	Signal										
Black	GND												
Yellow	DMX +												
Brown	DMX -												
Red	Not used												
Unplug the link cable from the first light DMX Out, unplug the terminator from the last light. Connect the terminator into DMX Out of the first light and measure the resistance. If resistance reading is between 120-180 Ohms move along to the next light working your way up to the last light to identify where there is a break in the DMX chain that could be due to broken wiring or loose connections.													
If all of the above is ok, most likely there is a fault with the DMX controller, ensure the controller is working fine – please refer to the controller manual troubleshooting guide for more information.	Faulty DMX Controller	Contact your dealer											

7 Appendix

7.1 OVERALL DIMENSIONS

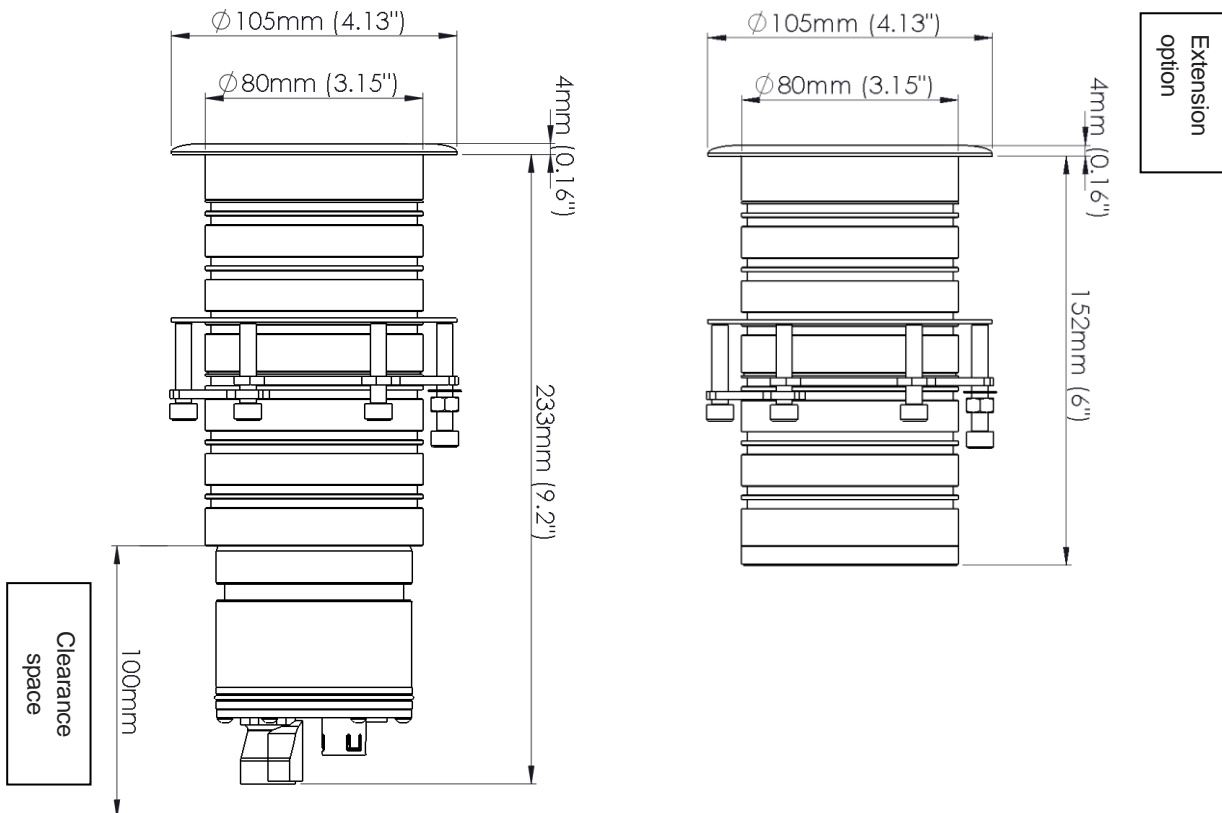
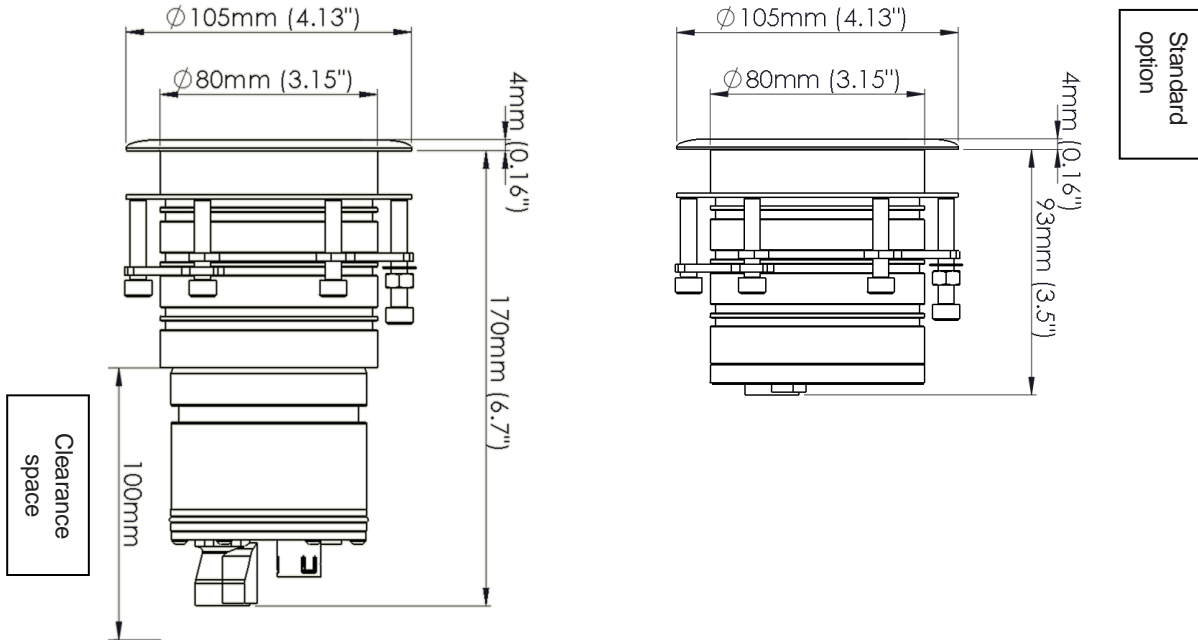

7.2 ESSENTIAL TEST

! Perform this bonding check after installation of the light and before moving the vessel back into the water.

Refer to bonding information in the installation sections in this manual. If in doubt, please contact OceanLED.

1. Connect the light assembly to the cathodic protection system as explained in Section 4.
2. Measure the electrical continuity between the front bezel and the sacrificial anode. This test should give a reading of up to 0.5 Ω (Ohms). This procedure will guarantee electrical continuity between the front bezel, the mounting tube and sacrificial anode.

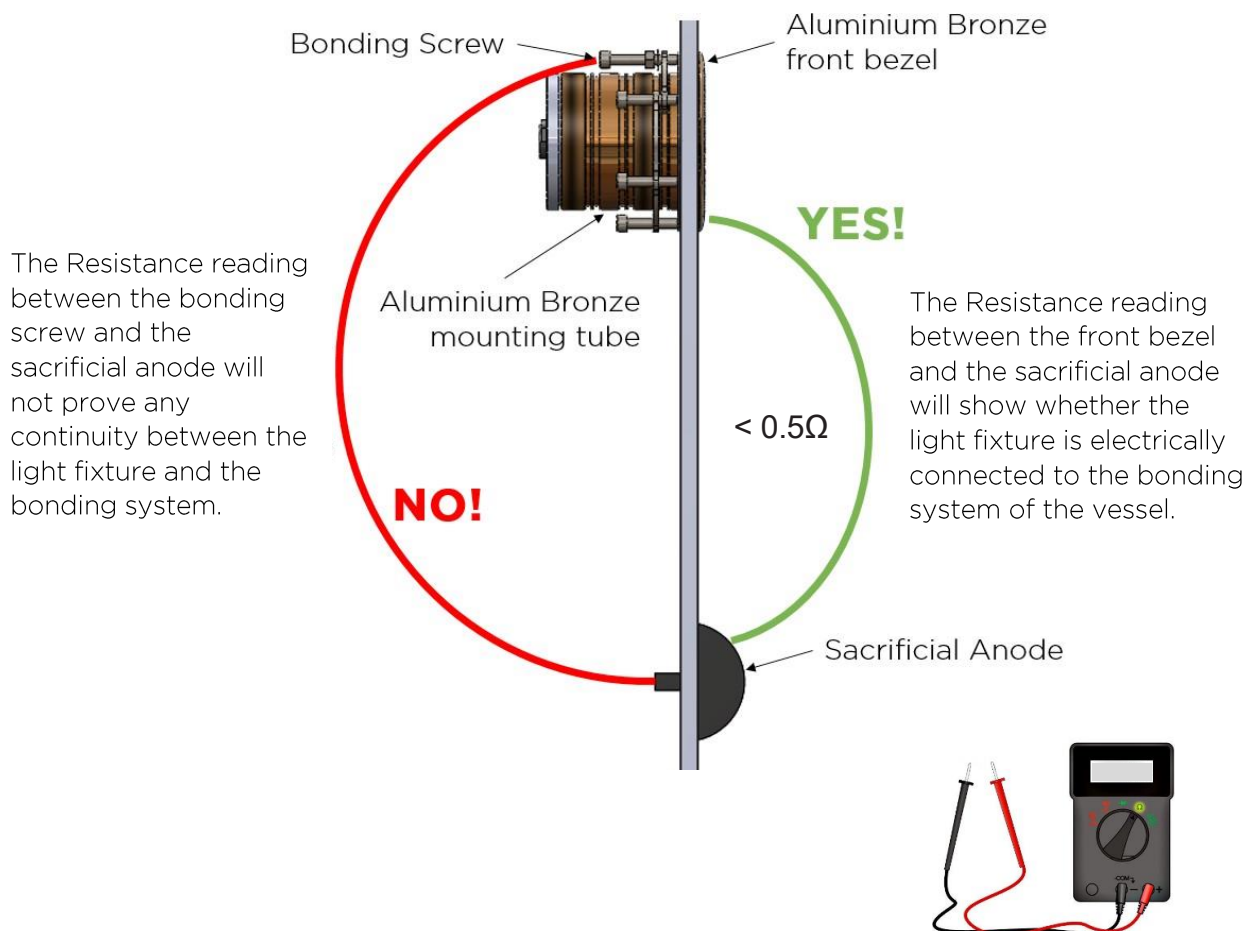

If you have any questions regarding the above, please contact OceanLED:

+44 (0) 1455 637505 or info@oceanled.com

7.3 LIGHT SETUP

The Explore Light Choice Diagram is also available at www.oceanled.com

Choose between Dual Midnight Blue / Ultra White or RGBW Colours DMX

LIGHT



OPTION 1

Explore XFM (Dual)
• Light Assembly

OPTION 2

Explore XFM (Colours)
• Light Assembly

ANGLE



Choose Internal Beam Angling

OPTION 1

0°
#E6009BW
• E6 Dual - 0°
#E6009CD
• E6 Colours - 0°

OPTION 2

10°
#E7019BW
• E7 Dual - 10°
#E7019CD
• E7 Colours - 10°

OPTION 3

20°
#E7029BW
• E7 Dual - 20°
#E7029CD
• E7 Colours - 20°

OPTION 4

30°
#E7039BW
• E7 Dual - 30°
#E7039CD
• E7 Colours - 30°

OPTION 5

40°
#E7049BW
• E7 Dual - 40°
#E7049CD
• E7 Colours - 40°

OPTION 6

50°
#E7059BW
• E7 Dual - 50°
#E7059CD
• E7 Colours - 50°



Choose either DC or AC Power Kits

POWER



OPTION 1

#019903
DC POWER KIT (1.5m)
• DC Power Cable
• Fuse Kit

OPTION 2

#019904
AC POWER KIT (1.5m)
• Power Pack
• AC Power Link Cable

Continued on the next page

Choose the method of how you control your lights

(Each Controller option comes with a 5m Control Input Cable Kit - Option 1)

CONTROL



OPTION 1

#012923
Switch / 3rd Party Control Input Kit
• Control Input Cable
• Terminator

OPTION 2

See OceanDMX RC Guide for options
OceanDMX RC Explore Kit
• OceanDMX RC Remote
• OceanDMX RC Receiver

OPTION 3

#013003 (Black)
#013003W (White)
OceanDMX TP (Dual)
• DMX Touch Controller
• #012923 Control Input Kit

OPTION 4

#013001 (Black)
#013001W (White)
OceanDMX TP (Colours)
• DMX Touch Controller
• #012923 Control Input Kit

OPTION 5

#013011 (Black Panel)
#013011W (White Panel)
OceanDMX WTP PLUS (Dual Colour)
• DMX WiFi Controller
• #012923 Control Input Kit

OPTION 6

#013010 (Black Panel)
#013010W (White Panel)
OceanDMX WTP PLUS (Colours)
• DMX WiFi Controller
• #012923 Control Input Kit



LINK



Select quantity of Control Link Cables based on quantity of lights

(N.B. You need 1 Link Cable less than the number of lights fitted)

OPTION 1

#012924
Control Link Cable (3m)
Select the quantity required (N.B. 1 cable less than No. of lights)

OPTION 2

#012925
Control Link Cable (5m)
Select the quantity required (N.B. 1 cable less than No. of lights)

OPTION 3

#012926
Control Link Cable (10m)
Select the quantity required (N.B. 1 cable less than No. of lights)

OPTION 4

#012927
Control Link Cable (15m)
Select the quantity required (N.B. 1 cable less than No. of lights)

OPTION 5

#012928
Control Link Cable (20m)
Select the quantity required (N.B. 1 cable less than No. of lights)

7.4 CABLE GAUGE CHART 12V

Supply & Return Cable Conductor Size Chart 3% drop for when using 12V DC supply											
Cable length (feet)*	Circuit Current										
	2 Amp	4 Amp	6 Amp	8 Amp	10 Amp	15 Amp	20 Amp	25 Amp	30 Amp	40 Amp	50 Amps
0-5	18 AWG	18 AWG	16 AWG	16 AWG	14 AWG	12 AWG	12 AWG	10 AWG	10 AWG	8 AWG	8 AWG
5-10	18 AWG	16 AWG	14 AWG	12 AWG	12 AWG	10 AWG	8 AWG	8 AWG	6 AWG	6 AWG	4 AWG
10-15	16 AWG	14 AWG	12 AWG	10 AWG	10 AWG	8 AWG	6 AWG	6 AWG	4 AWG	4 AWG	2 AWG
15-20	16 AWG	12 AWG	10 AWG	10 AWG	8 AWG	6 AWG	6 AWG	4 AWG	4 AWG	2 AWG	2 AWG
20-25	14 AWG	12 AWG	10 AWG	8 AWG	8 AWG	6 AWG	4 AWG	4 AWG	2 AWG	2 AWG	1 AWG
25-30	14 AWG	10 AWG	10 AWG	8 AWG	6 AWG	4 AWG	4 AWG	2 AWG	2 AWG	1 AWG	0 AWG
30-35	14 AWG	10 AWG	8 AWG	8 AWG	6 AWG	4 AWG	4 AWG	2 AWG	2 AWG	1 AWG	0 AWG
35-40	12 AWG	10 AWG	8 AWG	6 AWG	6 AWG	4 AWG	2 AWG	2 AWG	1 AWG	0 AWG	2/0 AWG
40-45	12 AWG	10 AWG	8 AWG	6 AWG	4 AWG	4 AWG	2 AWG	2 AWG	1 AWG	0 AWG	2/0 AWG
45-50	12 AWG	8 AWG	6 AWG	6 AWG	4 AWG	2 AWG	2 AWG	1 AWG	0 AWG	2/0 AWG	3/0 AWG
50-55	12 AWG	8 AWG	6 AWG	6 AWG	4 AWG	2 AWG	2 AWG	1 AWG	0 AWG	2/0 AWG	3/0 AWG
55-60	10 AWG	8 AWG	6 AWG	4 AWG	4 AWG	2 AWG	1 AWG	0 AWG	0 AWG	3/0 AWG	4/0 AWG
60-65	10 AWG	8 AWG	6 AWG	4 AWG	4 AWG	2 AWG	1 AWG	0 AWG	2/0 AWG	3/0 AWG	4/0 AWG
65-70	10 AWG	8 AWG	6 AWG	4 AWG	4 AWG	2 AWG	1 AWG	0 AWG	2/0 AWG	3/0 AWG	4/0 AWG
70-75	10 AWG	6 AWG	4 AWG	4 AWG	2 AWG	2 AWG	0 AWG	2/0 AWG	2/0 AWG	4/0 AWG	
75-80	10 AWG	6 AWG	4 AWG	4 AWG	2 AWG	1 AWG	0 AWG	2/0 AWG	3/0 AWG	4/0 AWG	
80-85	10 AWG	6 AWG	4 AWG	4 AWG	2 AWG	1 AWG	0 AWG	2/0 AWG	3/0 AWG	4/0 AWG	
85-90	10 AWG	6 AWG	4 AWG	4 AWG	2 AWG	1 AWG	0 AWG	2/0 AWG	3/0 AWG	4/0 AWG	
90-95	8 AWG	6 AWG	4 AWG	2 AWG	2 AWG	1 AWG	2/0 AWG	3/0 AWG	3/0 AWG		
95-100	8 AWG	6 AWG	4 AWG	2 AWG	2 AWG	0 AWG	2/0 AWG	3/0 AWG	4/0 AWG		

*One-way cable length from supply (usually battery) to load.

7.5 CABLE GAUGE CHART 24V

Supply & Return Cable Conductor Size Chart 3% drop for when using 24V DC supply											
Cable length (feet)*	Circuit Current										
	2 Amp	4 Amp	6 Amp	8 Amp	10 Amp	15 Amp	20 Amp	25 Amp	30 Amp	40 Amp	50 Amps
0-5	18 AWG	18 AWG	18 AWG	18 AWG	18 AWG	16 AWG	14 AWG	14 AWG	12 AWG	12 AWG	10 AWG
5-10	18 AWG	18 AWG	16 AWG	16 AWG	14 AWG	12 AWG	12 AWG	10 AWG	10 AWG	8 AWG	8 AWG
10-15	18 AWG	16 AWG	14 AWG	14 AWG	12 AWG	12 AWG	10 AWG	8 AWG	8 AWG	6 AWG	6 AWG
15-20	18 AWG	16 AWG	14 AWG	12 AWG	12 AWG	10 AWG	8 AWG	8 AWG	6 AWG	6 AWG	4 AWG
20-25	18 AWG	14 AWG	12 AWG	12 AWG	10 AWG	8 AWG	8 AWG	6 AWG	6 AWG	4 AWG	4 AWG
25-30	16 AWG	14 AWG	12 AWG	10 AWG	10 AWG	8 AWG	6 AWG	6 AWG	4 AWG	4 AWG	2 AWG
30-35	16 AWG	14 AWG	12 AWG	10 AWG	10 AWG	8 AWG	6 AWG	6 AWG	4 AWG	4 AWG	2 AWG
35-40	16 AWG	12 AWG	10 AWG	10 AWG	8 AWG	6 AWG	6 AWG	4 AWG	4 AWG	2 AWG	2 AWG
40-45	14 AWG	12 AWG	10 AWG	10 AWG	8 AWG	6 AWG	4 AWG	4 AWG	4 AWG	2 AWG	2 AWG
45-50	14 AWG	12 AWG	10 AWG	8 AWG	8 AWG	6 AWG	4 AWG	4 AWG	2 AWG	2 AWG	1 AWG
50-55	14 AWG	12 AWG	10 AWG	8 AWG	8 AWG	6 AWG	4 AWG	4 AWG	2 AWG	2 AWG	1 AWG
55-60	14 AWG	10 AWG	10 AWG	8 AWG	6 AWG	4 AWG	4 AWG	2 AWG	2 AWG	1 AWG	0 AWG
60-65	14 AWG	10 AWG	8 AWG	8 AWG	6 AWG	4 AWG	4 AWG	2 AWG	2 AWG	1 AWG	0 AWG
65-70	14 AWG	10 AWG	8 AWG	8 AWG	6 AWG	4 AWG	4 AWG	2 AWG	2 AWG	1 AWG	0 AWG
70-75	12 AWG	10 AWG	8 AWG	6 AWG	6 AWG	4 AWG	2 AWG	2 AWG	2 AWG	0 AWG	2/0 AWG
75-80	12 AWG	10 AWG	8 AWG	6 AWG	6 AWG	4 AWG	2 AWG	2 AWG	1 AWG	0 AWG	2/0 AWG
80-85	12 AWG	10 AWG	8 AWG	6 AWG	6 AWG	4 AWG	2 AWG	2 AWG	1 AWG	0 AWG	2/0 AWG
85-90	12 AWG	10 AWG	8 AWG	6 AWG	4 AWG	4 AWG	2 AWG	2 AWG	1 AWG	0 AWG	2/0 AWG
90-95	12 AWG	8 AWG	8 AWG	6 AWG	4 AWG	4 AWG	2 AWG	1 AWG	1 AWG	2/0 AWG	2/0 AWG
95-100	12 AWG	8 AWG	6 AWG	6 AWG	4 AWG	2 AWG	2 AWG	1 AWG	0 AWG	2/0 AWG	3/0 AWG

*One-way cable length from supply (usually battery) to load.

7.6 EXPLORE E6/E7 XFM ANGLED BEAM DETAILS

Mounting Tube follows Hull geometry while Light Optics angle the beam in the desired direction

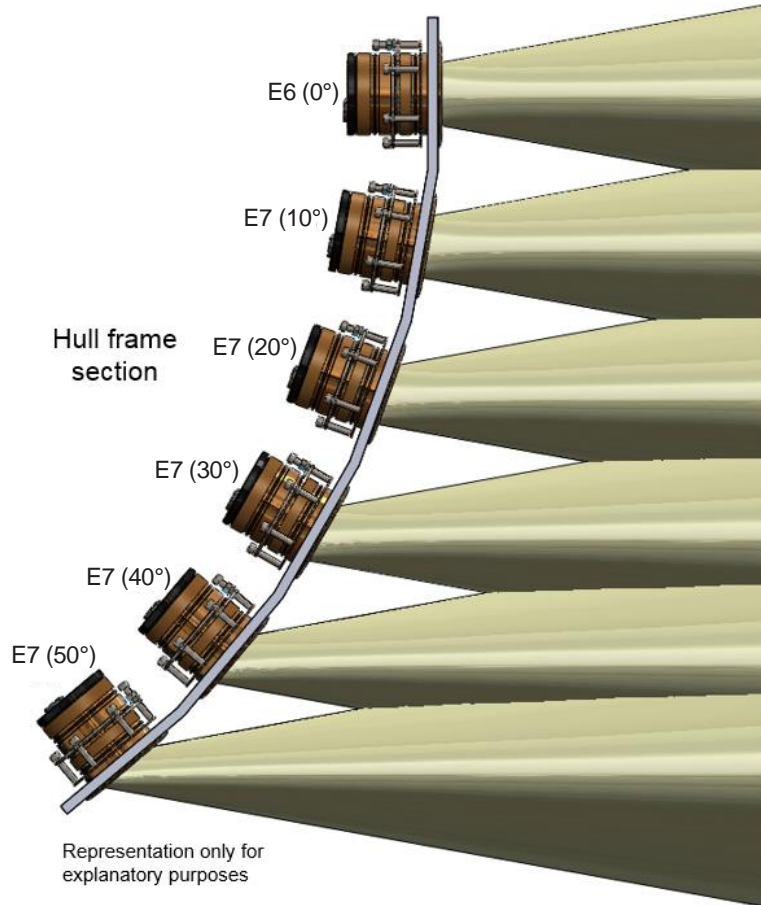

The LED Indicator on the back of the light cartridge is used as reference for the Light Beam orientation as shown below

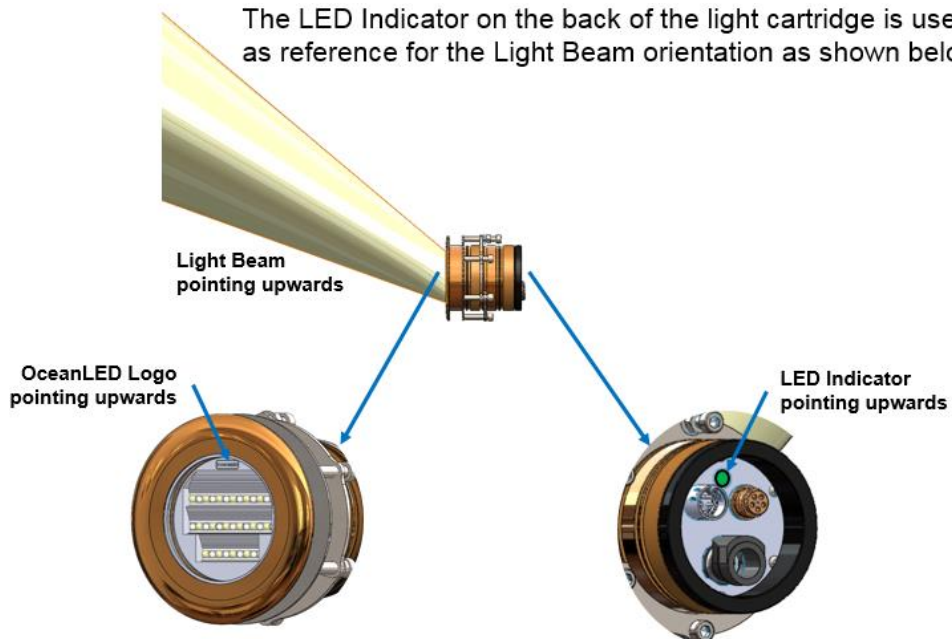

NOTE: Rotating the light by 180° on its longitudinal axis will result in a downwards orientated light beam

7.7 EXAMPLE OF THE DC INSTALLATION OF MIXED XFM AND TH E6 & E7 LIGHTS

Explore XFM Lighting System Control Options

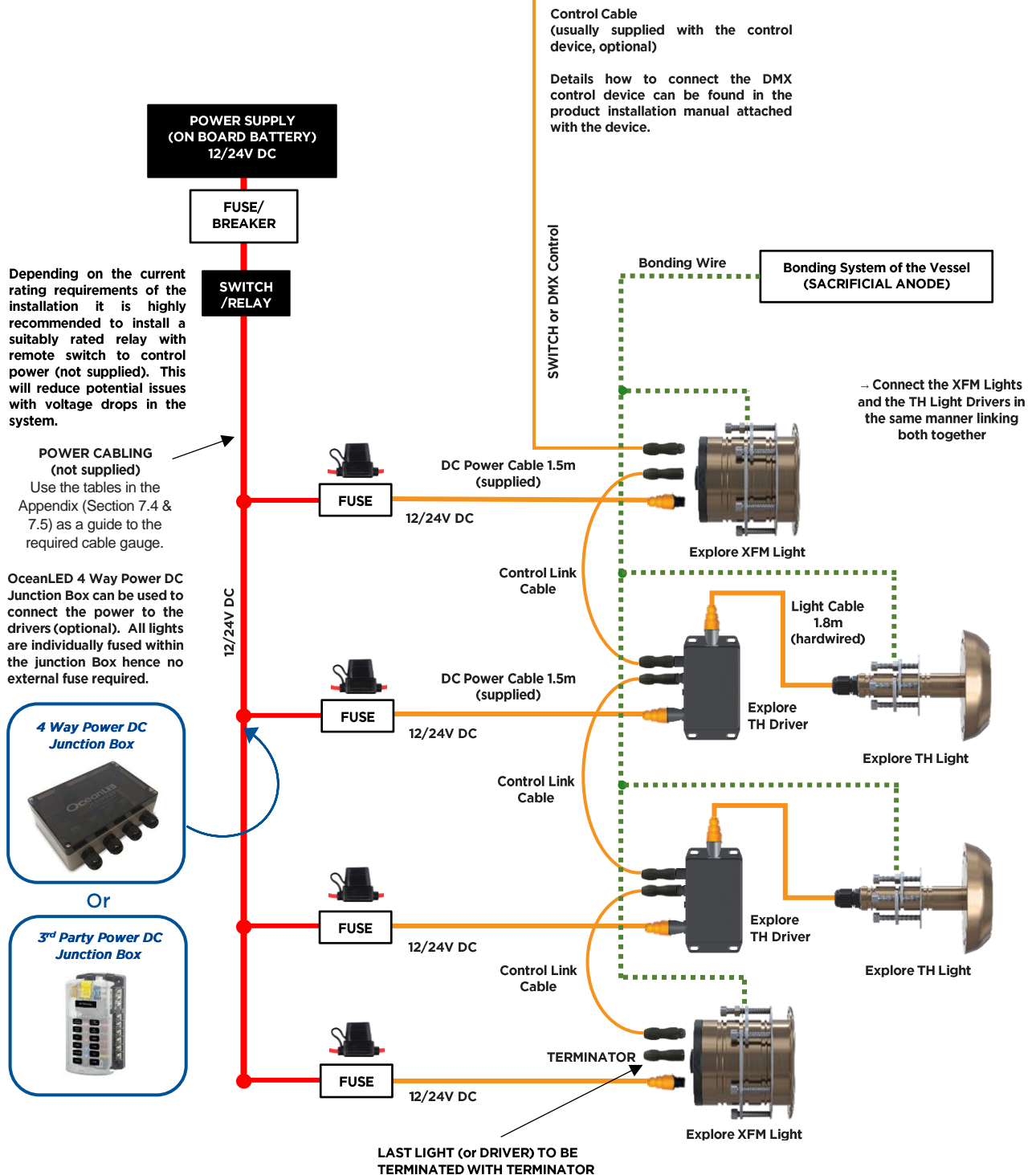

8 Warranty

Please remove this page and keep for your files

For technical assistance:

Europe: service@oceanled.com

The Americas: warranty@oceanledusa.com

Warranty Serial Code(s):

© 2022 Ocean LED Marine LTD
All Rights Reserved

Specifications are subject to change without notice.

Trademarks are the property of Ocean LED Marine LTD

Ocean LED Marine LTD
Unit 1 Jacknell Road
Dodwells Bridge Industrial Estate
Hinckley,
Leicestershire LE10 3BS
United Kingdom

Tel: +44 (0) 1455 637505
Fax: +44 (0) 1455 238553
sales@oceanled.com

Ocean LED USA LLC
778 South Military Trail
Deerfield Beach
Florida
FL 33442-3025
USA

Tel: +1 954.523.2250
Fax: +1 954.523.2249
sales@oceanledusa.com

www.oceanled.com