



M300 SERIES

INSTALLATION & OPERATION INSTRUCTIONS



English (en-US)

Date: 08-2019

Document number: 71004-1

© 2019 FLIR Systems, Inc.



Trademark and patents notice

Raymarine, Tacktick, Clear Pulse, Truzoom, SeaTalk, SeaTalk^{hs}, SeaTalkng, and Micronet, are registered or claimed trademarks of Raymarine Belgium.

FLIR, LightHouse, DownVision, SideVision, RealVision, HyperVision, Dragonfly, Element, Quantum, Axiom, Instalert, Infrared Everywhere, The World's Sixth Sense and ClearCruise are registered or claimed trademarks of FLIR Systems, Inc.

All other trademarks, trade names, or company names referenced herein are used for identification only and are the property of their respective owners.

This product is protected by patents, design patents, patents pending, or design patents pending.

Patents notice

This product is covered by one or more of US Patent Nos: 7470904; 7034301; 6812465; 7470902; 6929410 and other patents pending, or design patents pending.

Fair Use Statement

You may print no more than three copies of this manual for your own use. You may not make any further copies or distribute or use the manual in any other way including without limitation exploiting the manual commercially or giving or selling copies to third parties.

Export control

M300 Series thermal cameras are controlled by US export laws.

There are special versions of the system that are approved for international distribution and travel. Please contact FLIR customer support if you have any questions.

Contact details can be found on the FLIR website, www.flir.com.

Export Administration Regulations (EAR)

This document is controlled to FLIR Technology Level 1. The information contained in this document pertains to a dual use product controlled for export by the Export Administration Regulations (EAR). FLIR trade secrets contained herein are subject to disclosure restrictions as a matter of law. Diversion contrary to US law is prohibited. US Department of Commerce authorization is not required prior to export or transfer to foreign persons or parties unless otherwise prohibited.

Software updates

Important: Check the FLIR website for the latest software releases for your product.

www.flir.com/marine/support

Product handbooks

The latest versions of all English and translated handbooks are available to download in PDF format from www.flir.com/marine/support. Please check the website to ensure you have the latest handbooks.

Copyright ©2019 FLIR Systems, Inc. All rights reserved.

English (en-US)

Document number: 71004-1

AA;17830;2019-08-09T17:42:23

Contents

Chapter 1 Important information 9

Cleaning the camera	10
Inspecting the thermal camera.....	10
Water ingress	10
Disclaimer.....	10
EMC installation guidelines.....	10
Suppression ferrites.....	11
Connections to other equipment.....	11
Declaration of Conformity.....	11
Product disposal.....	11
Warranty registration	12
IMO and SOLAS	12
Technical accuracy	12

Chapter 2 Document and product information..... 13

2.1 Document information.....	14
Applicable products	14
Additional system components	14
Product documentation.....	14
2.2 System overview.....	15
2.3 Product overview	15
M300 (single payload)	15
M300 (dual payload).....	16
2.4 Parts supplied.....	17
M300 Series camera.....	17
Parts supplied — JCU-2 (available separately).....	17
2.5 Compatible joystick controllers (JCU).....	18
2.6 Compatible multifunction displays	18

Multifunction display software requirements	18
---	----

Chapter 3 Installation 19

3.1 General location requirements	20
Compass safe distance.....	20
3.2 Tools required.....	21
3.3 Product dimensions	21
M300 Series.....	21
M300 Series with optional mounting riser	21
JCU-2 (available separately).....	22
3.4 Camera orientation.....	22
3.5 Camera mounting	22
Location requirements.....	22
Mounting the camera	23
Mounting the camera with the optional mounting riser.....	24
3.6 JCU-2 Mounting	25
Location requirements.....	25
Removing the keypad mat.....	25
Flush mounting the keypad.....	25
Surface mounting the keypad	26
Fitting the keypad mat.....	26

Chapter 4 Connections..... 27

4.1 General cabling guidance.....	28
Cable types and length.....	28
Cable routing.....	28
Strain relief.....	28
Circuit isolation.....	28
Cable shielding.....	28

HD-SDI cable connection.....	28	6.2 Setting up a network connection to the camera.....	48
4.2 Connections overview	29	6.3 Logging in to the Web browser user interface	49
Connecting cables	30	First time login.....	49
Orientation of right-angled connectors.....	30	6.4 Video feed.....	50
4.3 Video connections.....	30	6.5 Camera settings menus.....	50
Video and network cables.....	31	6.6 System settings.....	50
4.4 NMEA 0183 connection.....	32	6.7 Troubleshoot.....	51
4.5 Typical systems.....	33	Setting a static IP address	51
4.6 Network connections.....	33	Chapter 7 JCU-2 operation	53
Non-RayNet systems.....	33	7.1 Main Menu	54
RayNet systems with Raymarine LightHouse 3 multifunction displays (MFDs).....	36	7.2 JCU-2 controls overview.....	54
4.7 Power connection	37	Configuring JCU-2 user-programmable buttons (UPBs).....	55
Power distribution	37	Chapter 8 MFD operation	57
In-line fuse and thermal breaker ratings	39	8.1 Overview	58
Grounding — Dedicated drain wire	39	8.2 ClearCruise thermal analytics	58
Chapter 5 Camera control options and status icons.....	41	8.3 Auto-tracking	58
5.1 Camera control options	42	Chapter 9 Maintenance.....	59
5.2 Camera image	42	9.1 Service and maintenance.....	60
Thermal Camera	42	9.2 Cleaning the camera	60
Camera status icons.....	42	Chapter 10 System checks and troubleshooting.....	61
Image adjustments.....	44	10.1 Thermal camera troubleshooting	62
5.3 Camera control	45	10.2 FLIR Maritime product support and servicing.....	63
Pan, tilt and zoom	45	Chapter 11 Technical specification.....	65
Home position.....	45	11.1 M300 Series cameras	66
Surveillance mode	45	Technical specification	66
Chapter 6 Web interface operation	47	11.2 JCU-2.....	67
6.1 Web browser user interface overview	48		

Technical specification 67

Chapter 12 Spares and accessories..... 69

12.1 M300 Series camera spares and accessories 70
12.2 RayNet to RJ45 adapter cables 71
12.3 RayNet to RayNet cables and connectors..... 73

Chapter 1: Important information



Warning: Product installation and operation

- This product must be installed and operated in accordance with the instructions provided. Failure to do so could result in personal injury, damage to your vessel and/or poor product performance.
- Certified installation by an approved installer is recommended. A certified installation qualifies for enhanced product warranty benefits. Contact your dealer for further details, and refer to the separate warranty document packed with your product.



Warning: Corrosion

To avoid accelerated galvanic corrosion of the product, ensure that a non-metallic isolation mount is used when fitting the product directly to large stainless steel platforms/mounts, or directly to steel construction vessels.



Warning: Potential ignition source

This product is NOT approved for use in hazardous/flammable atmospheres. Do NOT install in a hazardous/flammable atmosphere (such as in an engine room or near fuel tanks).



Warning: Product grounding

Before applying power to this product, ensure it has been correctly grounded, in accordance with the instructions provided.



Warning: Positive ground systems

Do not connect this unit to a system which has positive grounding.



Warning: Power supply voltage

Connecting this product to a voltage supply greater than the specified maximum rating may cause permanent damage to the unit. Refer to the *Technical specification* section for voltage rating.



Warning: Switch off power supply

Ensure the vessel's power supply is switched OFF before starting to install this product. Do NOT connect or disconnect equipment with the power switched on, unless instructed in this document.



Warning: Entrapment hazard

This product features moving parts that provide a potential entrapment hazard. Keep clear of moving parts at all times.



Warning: Ensure safe navigation

This product is intended only as an aid to navigation and must never be used in preference to sound navigational judgment. Only official government charts and notices to mariners contain all the current information needed for safe navigation, and the captain is responsible for their prudent use. It is the user's responsibility to use official government charts, notices to mariners, caution and proper navigational skill when operating this or any other FLIR product.



Warning: Maintain a permanent watch

Always maintain a permanent watch, this will allow you to respond to situations as they develop. Failure to maintain a permanent watch puts yourself, your vessel and others at serious risk of harm.

Caution: Do not open the unit

The unit is factory sealed to protect against atmospheric humidity, suspended particulates and other contaminants. It is important that you do not open the unit or remove the casing for any reason. Opening the unit will:

- compromise the seal with possible damage to the unit, and
- void the manufacturer's warranty.

Caution: Power supply protection

When installing this product ensure the power source is adequately protected by means of a suitably-rated fuse or automatic circuit breaker.



Warning: Ensure all equipment has isolated power supply

This product features an isolated power supply. To prevent potential damage to equipment, it is recommended that any external equipment connected to this product also features an isolated power supply.

Caution: Service and maintenance

This product contains no user serviceable components. Please refer all maintenance and repair to authorized **FLIR** dealers. Unauthorized repair may affect your warranty.

Caution: Sun covers

- If your product is supplied with a sun cover, to protect against the damaging effects of ultraviolet (UV) light, always fit the sun cover when the product is not in use.
- To avoid potential loss, sun covers must be removed when travelling at high speed, whether in water or when the vessel is being towed.

Cleaning the camera

The camera housing and lens will require occasional cleaning. You should clean the lens when image quality degradation is noticed or excessive contaminant buildup is seen. Clean the interface between the yoke and base often to prevent accumulation of debris or salt deposits.

When cleaning this product:

- Do NOT wipe the lens window with a dry cloth, or with abrasive materials such as paper or scrub brushes, as this could scratch the coating.
- Do NOT use acid or ammonia based products.
- Do NOT pressure wash.

Particular care should be taken when cleaning the lens window, this has a protective anti-reflective coating which may be damaged by improper cleaning.

1. Switch off the power to the unit.
2. Clean the camera body with a clean, soft cotton cloth. You can moisten the cloth and use a mild detergent if required.
3. Clean the camera lens.
 - Rinse the lens with fresh water to remove all dirt particles and salt deposits, and allow to dry naturally.
 - If any spots or smears remain, very gently wipe the lens window with a clean microfibre cloth or soft cotton cloth.
 - If necessary, use isopropyl alcohol (IPA) or a mild detergent to remove any remaining spots or marks.

Inspecting the thermal camera

Routinely inspect the camera and its mounting surface to ensure that it is installed securely, that the coated surfaces are intact, and that there are no signs of corrosion.

When the camera is powered off, grasp it firmly at the base and confirm it is rigid and secure. Then hold the camera above the base and confirm it will rotate freely and without noticeable wobble or looseness around the pan bearing.

Water ingress

Water ingress disclaimer

Although the waterproof rating capacity of this product meets the stated standard (refer to the product's *Technical Specification*), water intrusion and subsequent equipment failure may occur if the product is subjected to commercial high-pressure washing. **FLIR** will not warrant products subjected to high-pressure washing.

Disclaimer

FLIR does not warrant that this product is error-free or that it is compatible with products manufactured by any person or entity other than **FLIR**.

FLIR is not responsible for damages or injuries caused by your use or inability to use the product, by the interaction of the product with products manufactured by others, or by errors in information utilized by the product supplied by third parties.

EMC installation guidelines

FLIR equipment and accessories conform to the appropriate Electromagnetic Compatibility (EMC) regulations, to minimize electromagnetic interference

between equipment and minimize the effect such interference could have on the performance of your system

Correct installation is required to ensure that EMC performance is not compromised.

Note: In areas of extreme EMC interference, some slight interference may be noticed on the product. Where this occurs the product and the source of the interference should be separated by a greater distance.

For **optimum** EMC performance we recommend that wherever possible:

- **FLIR** equipment and cables connected to it are:
 - At least 1 m (3 ft) from any equipment transmitting or cables carrying radio signals e.g. VHF radios, cables and antennas. In the case of SSB radios, the distance should be increased to 7 ft (2 m).
 - More than 2 m (7 ft) from the path of a radar beam. A radar beam can normally be assumed to spread 20 degrees above and below the radiating element.
- The product is supplied from a separate battery from that used for engine start. This is important to prevent erratic behavior and data loss which can occur if the engine start does not have a separate battery.
- **FLIR** specified cables are used.
- Cables are not cut or extended, unless doing so is detailed in the installation manual.

Note: Where constraints on the installation prevent any of the above recommendations, always ensure the maximum possible separation between different items of electrical equipment, to provide the best conditions for EMC performance throughout the installation

Suppression ferrites

- Cables may be pre-fitted or supplied with suppression ferrites. These are important for correct EMC performance. If ferrites are supplied separately to the cables (i.e. not pre-fitted), you must fit the supplied ferrites, using the supplied instructions.
- If a ferrite has to be removed for any purpose (e.g. installation or maintenance), it must be replaced in the original position before the product is used.
- Use only ferrites of the correct type, supplied by the manufacturer or its authorized dealers.
- Where an installation requires multiple ferrites to be added to a cable, additional cable clips should be used to prevent stress on the connectors due to the extra weight of the cable.
- If your camera installation requires long cable runs, you may need to fit additional ferrites to maintain acceptable EMC performance.

Connections to other equipment

Requirement for ferrites on non-FLIR cables

If your **FLIR** equipment is to be connected to other equipment using a cable not supplied by **FLIR**, a suppression ferrite **MUST** always be attached to the cable near the **FLIR** unit.

Declaration of Conformity

FLIR Belgium BVBA declares that the following products are in compliance with the EMC Directive 2014/30/EU:

- M364C 30 Hz dual payload thermal camera, part number E70518
- M364C 9 Hz dual payload thermal camera, part number E70519

- M364C 30 Hz dual payload thermal camera, part number E70520
- M364C 9 Hz dual payload thermal camera, part number E70521
- M364 30 Hz single payload thermal camera, part number E70525
- M364 9 Hz single payload thermal camera, part number E70526
- M332 30 Hz single payload thermal camera, part number E70527
- M332 9 Hz single payload thermal camera, part number E70528
- M300C 30 Hz single payload camera, part number E70605

The original Declaration of Conformity certificate may be viewed on the relevant product page at www.flir.com/marine.

Product disposal

Dispose of this product in accordance with the WEEE Directive.

The Waste Electrical and Electronic Equipment (WEEE) Directive requires the recycling of waste electrical and electronic equipment which contains materials, components and substances that may be hazardous and present a risk to human health and the environment when WEEE is not handled correctly.



Equipment marked with the crossed-out wheeled bin symbol indicates that the equipment should not be disposed of in unsorted household waste.

Local authorities in many regions have established collection schemes under which residents can dispose of waste electrical and electronic equipment at a recycling center or other collection point.

For more information about suitable collection points for waste electrical and electronic equipment in your region, refer to the Raymarine website: www.raymarine.eu/recycling.

our policy of continuous product improvement may change specifications without notice. As a result, FLIR cannot accept liability for any differences between the product and this document. Please check the FLIR website (www.flir.com/marine/support) to ensure you have the most up-to-date version(s) of the documentation for your product.

Warranty registration

To register your FLIR product ownership, please visit www.flir.com and register online.

It is important that you register your product to receive full warranty benefits. Your unit package includes a bar code label indicating the serial number of the unit. You will need this serial number when registering your product online. You should retain the label for future reference.

IMO and SOLAS

The equipment described within this document is intended for use on leisure marine boats and workboats NOT covered by International Maritime Organization (IMO) and Safety of Life at Sea (SOLAS) Carriage Regulations.

Technical accuracy

To the best of our knowledge, the information in this document was correct at the time it was produced. However, FLIR cannot accept liability for any inaccuracies or omissions it may contain. In addition,

Chapter 2: Document and product information

Chapter contents

- [2.1 Document information on page 14](#)
- [2.2 System overview on page 15](#)
- [2.3 Product overview on page 15](#)
- [2.4 Parts supplied on page 17](#)
- [2.5 Compatible joystick controllers \(JCU\) on page 18](#)
- [2.6 Compatible multifunction displays on page 18](#)

2.1 Document information

This document contains important information related to the installation and operation of your FLIR product.

The document includes information to help you:

- plan your installation and ensure you have all the necessary equipment;
- install and connect your product as part of a wider system of connected marine electronics;
- use your product along with an appropriate video monitor, joystick control unit (JCU), web browser, or multifunction display (MFD).
- troubleshoot problems and obtain technical support if required.

This and other FLIR product documents are available to download in PDF format from www.flir.com/marine/support.

Applicable products

This document is applicable to the following products:

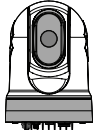
Single Payload			
	Part number	Name	Description
	E70528	M332 (9 Hz)	24° 320 IR
	E70527	M332 (30 Hz)	
	E70526	M364 (9 Hz)	24° 640 IR
	E70525	M364 (30 Hz)	

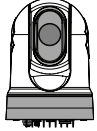
Single Payload			
	Part number	Name	Description
	E70605	M300C (30 Hz)	30x 1080P DLTV

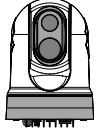
Dual Payload			
	Part number	Name	Description
	E70521	M364C LR (9 Hz)	18° 640 IR & 30x 1080P DLTV
	E70520	M364C LR (30 Hz)	
	E70519	M364C (9 Hz)	24° 640 IR & 30x 1080P DLTV
	E70518	M364C (30 Hz)	

Additional system components

M300 Series thermal cameras can be used in conjunction with the following optional items, available separately from FLIR:

- **JCU-2** joystick control unit: a remote keypad for FLIR thermal cameras (500-0398-10). The keypad interacts directly with supported thermal cameras, and does not require any other products (such as an MFD) to be present on the network. Each JCU-2 keypad can be paired with multiple thermal cameras, and each camera can be paired to multiple keypads.
- **JCU-1** and **JCU-3**: For more information on these remote keypads, refer to: [2.5 Compatible joystick controllers \(JCU\)](#)

Product documentation

The following documentation is applicable to your product:

Description	Part number
M300 Thermal Camera Installation and Operation Instructions Installation and operation of an M300 Series thermal camera and connection to a wider system of marine electronics.	71004
M300 Series surface mounting template Cut out template for mounting an M300 Series thermal camera.	77005
M300 Series riser mounting template Drill template for mounting the camera riser.	77006
LightHouse™ 3 MFD Advanced Operation Instructions Details the operation of the Video application for LightHouse™ 3-compatible multifunction displays.	81370

2.2 System overview

The camera has a flexible array of connection options to enable you to integrate it with your electronics system.

With the right combination of devices and connections, you can view and control the camera's image from the most convenient locations on your vessel.

The following illustration shows a very typical installation scenario. For more system configuration examples, ranging from small to large systems, refer to: [4.6 Network connections](#)

For an overview of the camera's video connection options, refer to: [4.3 Video connections](#)

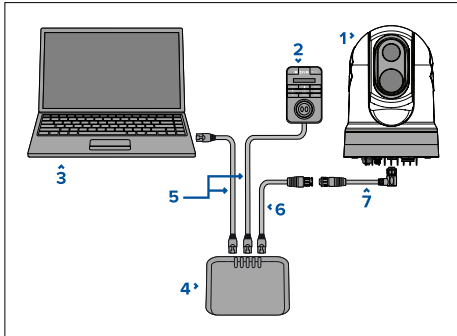

Note: Power connections are not shown in this illustration. The camera and the other devices shown require their own dedicated power connection.

	Description
1	M300 Series camera
2	Joystick control unit (e.g. JCU-2), available separately

	Description
3	Laptop (or other Ethernet-connected device running a web browser), available separately from third-party retailers
4	Ethernet network switch with PoE, available separately
5	RJ45-to-RJ45 Ethernet cable, available separately
6	RayNet-to-RJ45 adapter cable (120 mm / 4.7 in.) (supplied with camera)
7	Right angled RayNet-to-RayNet cable (3 m / 9.8 ft) (supplied with camera)

2.3 Product overview

M300 (single payload)

The M300 Series single payload variant is a maritime camera equipped with either a visible or thermal imaging system (depending on chosen model) for use on nearly any kind of vessel.

- **Visible** — provides a clear colour image in daylight conditions. For example, a visible camera can help you maintain a watch of your surroundings and zoom in on distant objects.
- **Thermal** — provides a clear image in low-light and no-light conditions. For example, a thermal camera can help you navigate at night or identify obstacles in areas of low visibility or even total darkness.

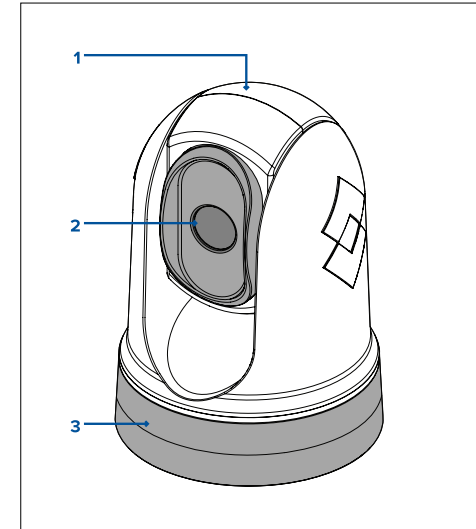

1. Tilt assembly.
2. Camera lens window.

3. Pan assembly.

The M300 Series system has the following key functions and features:

- IP connectivity to simplify installation and system integration.
- H264-encoded IP video stream.
- Pan and tilt operations with dedicated joystick control unit, multifunction display (MFD), or web browser.
- Automatic camera stabilization to suit changing conditions.
- Preset modes (Scenes) optimized for prevailing conditions.
- ClearCruise™ Object Detection — intelligent thermal analytics technology; provides audible and visual alerts when “non-water” objects are identified in the scene. (Requires a Raymarine® MFD running LightHouse™ 3 software or later.)
- ClearCruise™ Augmented Reality — feature places layers of digital information directly over the top of the video feed. Vessel data is used to generate informative text and images (flags) that overlap real-life objects. (Requires a Raymarine® MFD running LightHouse™ 3.7 software or later.)
- Automatic window heaters to de-ice the lens window in cold weather.
- 12 V or 24 V dc power.

M300 (dual payload)

The M300 Series dual payload variant is a maritime camera equipped with a visible and thermal imaging system for use on nearly any kind of vessel.

- **Visible** — provides a clear colour image in daylight conditions. For example, a visible camera can help you maintain a watch of your surroundings and zoom in on distant objects.
- **Thermal** — provides a clear image in low-light and no-light conditions. For example, a thermal

camera can help you navigate at night or identify obstacles in areas of low visibility or even total darkness.

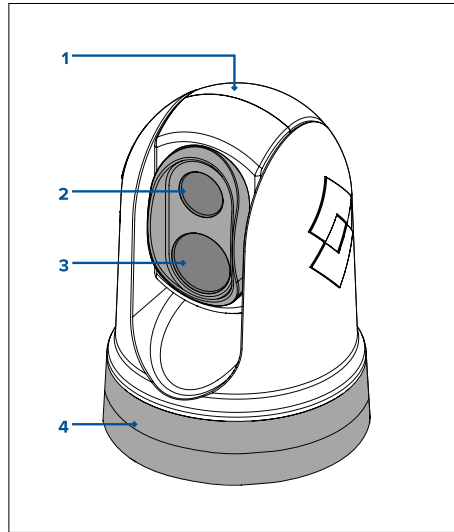

1. Tilt assembly.
2. Thermal camera lens window.
3. Visible camera lens window
4. Pan assembly.

The M300 Series system has the following key functions and features:

- IP connectivity to simplify installation and system integration.
- H264-encoded IP video stream.
- Pan and tilt operations with dedicated joystick control unit, multifunction display (MFD), or web browser.
- Automatic camera stabilization to suit changing conditions.

- Preset modes (Scenes) optimized for prevailing conditions.
- ClearCruise™ Object Detection — intelligent thermal analytics technology; provides audible and visual alerts when “non-water” objects are identified in the scene. (Requires a Raymarine® MFD running LightHouse™ 3 software or later.)
- ClearCruise™ Augmented Reality — feature places layers of digital information directly over the top of the video feed. Vessel data is used to generate informative text and images (flags) that overlap real-life objects. (Requires a Raymarine® MFD running LightHouse™ 3.7 software or later.)
- Automatic window heaters to de-ice the lens window in cold weather.
- 12 V or 24 V dc power.

2.4 Parts supplied

M300 Series camera

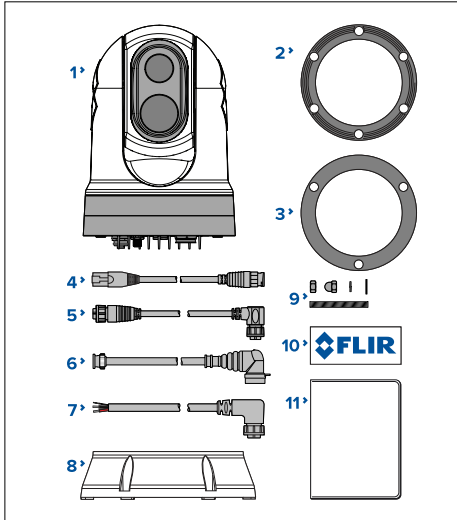

1. M300 Camera
2. Camera base-seal
3. Camera gasket
4. RayNet-to-RJ45 adaptor cable 120 mm (4.72 in.)
5. Right-angled RayNet-to-RayNet cable 3 m (9.8 ft.)
6. Right-angled BNC-to-BNC cable 3 m (9.8 ft.)
7. Right-angled 3-pin power cable 3 m (9.8 ft.)
8. Mounting riser
9. 3 x camera fixings: nuts, dome nuts, spring and flat washers, threaded studs

10. 2 x self-adhesive decals (for ball-down mounting only)

11. Documentation pack

Parts supplied — JCU-2 (available separately)

The parts supplied with the optional keypad are shown below.

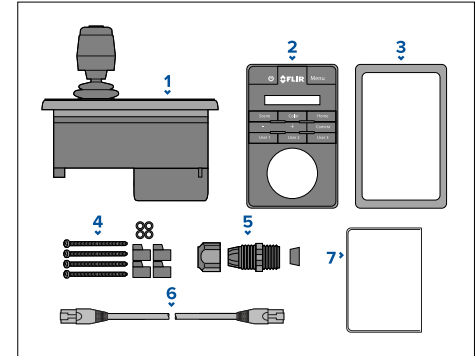

1. JCU-2 keypad
2. Keypad mat
3. Mounting gasket
4. 4 x mounting screws, rubber washers, mounting clamps
5. Cable gland nut
6. RJ45-to-RJ45 Ethernet cable, 7.6 m (25 ft)
7. Documentation pack

2.5 Compatible joystick controllers (JCU)

A joystick control unit (JCU) is available to purchase as an optional accessory. This enables you to control the camera remotely.

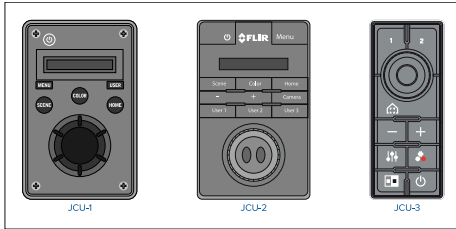

JCU variant	Part number	More information & manuals
JCU-1	500-0385-00	www.raymarine.com/view/index.cfm?id=17603
JCU-2	500-0398-10	www.flir.com/products/jcu2/
JCU-3	A80510	www.flir.com/products/jcu3/

2.6 Compatible multifunction displays

The camera image can be viewed and controlled directly from a Raymarine multifunction display (MFD).

Note: A Raymarine® LightHouse MFD is not required to use an M300 Series camera. However certain camera features may not be accessible without one.

This product is compatible with the following Raymarine® LightHouse 3 multifunction displays:

- eS Series (upgraded from LightHouse 2 to LightHouse 3).
- gS Series (upgraded from LightHouse 2 to LightHouse 3).
- Axiom
- Axiom Pro
- Axiom XL

Multifunction display software requirements

To use this product with a Raymarine® multifunction display (MFD), ensure that your MFD is running **Version 3.10** or later of the LightHouse™ 3 software.

Note:

- The latest LightHouse™ MFD software can be obtained by visiting www.raymarine.com/software.

Chapter 3: Installation

Chapter contents

- 3.1 General location requirements on page 20
- 3.2 Tools required on page 21
- 3.3 Product dimensions on page 21
- 3.4 Camera orientation on page 22
- 3.5 Camera mounting on page 22
- 3.6 JCU-2 Mounting on page 25

3.1 General location requirements

Important considerations when choosing a suitable location for your product.

The product should be mounted where it will be:

- protected from physical damage and excessive vibration.
- well ventilated and away from heat sources.

When choosing a location for the product, consider the following points to ensure reliable and trouble-free operation:

- **Access** — there must be sufficient space to enable cable connections to the product, avoiding tight bends in the cable.
- **Center line** — the product should be mounted as close to your vessel's central line as possible to provide a symmetrical view of all angles.

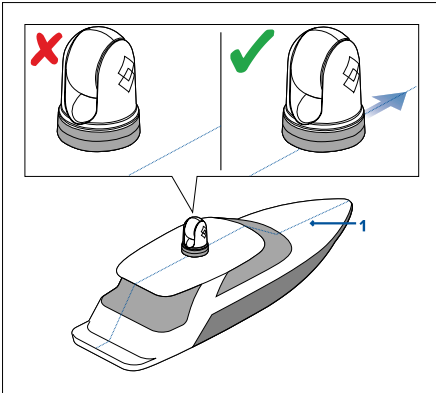

1. Vessel centre line.

- **Clear view** — the product should have a clear view of the water with minimal obstruction to the 360° view.

- **Diagnostics** — the product must be mounted in a location where the diagnostics LED is easily visible.

Note: Not all products include a diagnostics LED. Refer to the [Chapter 10 System checks and troubleshooting](#) for more information.

- **Electrical interference** — the product should be mounted far enough away from any equipment that may cause interference such as motors, generators and radio transmitters / receivers.
- **Magnetic compass** — refer to the *Compass safe distance* section in this document for advice on maintaining a suitable distance between this product and any compasses on your vessel.
- **Height** — the product should be mounted as high as practical, giving a clear view of all directions.
- **Power** — to keep cable runs to a minimum, the product must be located as close as possible to the vessel's dc power supply.
- **Mounting surface** — ensure the product is adequately supported on a secure surface. Refer to the weight information provided in the *Technical specification* for this product and ensure that the intended mounting surface is suitable for bearing the product weight. Do NOT mount units or cut holes in places which may damage the structure of the vessel.

Compass safe distance

To prevent potential interference with the vessel's magnetic compasses, ensure an adequate distance is maintained from the product.

When choosing a suitable location for the product you should aim to maintain the maximum possible distance from any compasses. Typically this distance should be at least 1 m (3.3 ft) in all directions. However for some smaller vessels it may not be possible to locate the product this far away from

a compass. In this situation, when choosing the installation location for your product, ensure that the compass is not affected by the product when it is in a powered state.

3.2 Tools required

The following tools are required for installation.

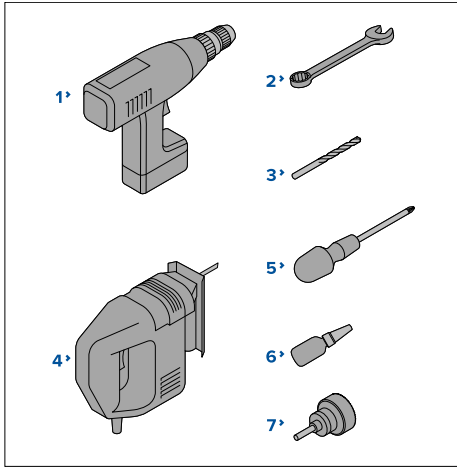

	Description
1	Drill
2	10 mm (0.39 in.) spanner
3	Drill bit (appropriate size dependent on thickness and material of mounting surface)
4	Jigsaw
5	Pozi-drive screwdriver
6	Thread-lock
7	50 mm (2 in.) Hole saw

3.3 Product dimensions

M300 Series

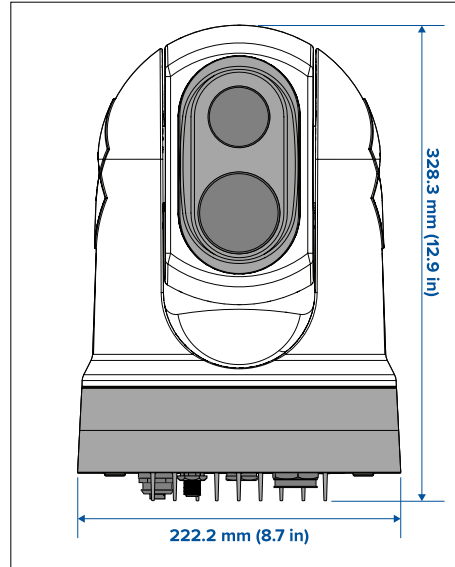

M300 Series with optional mounting riser

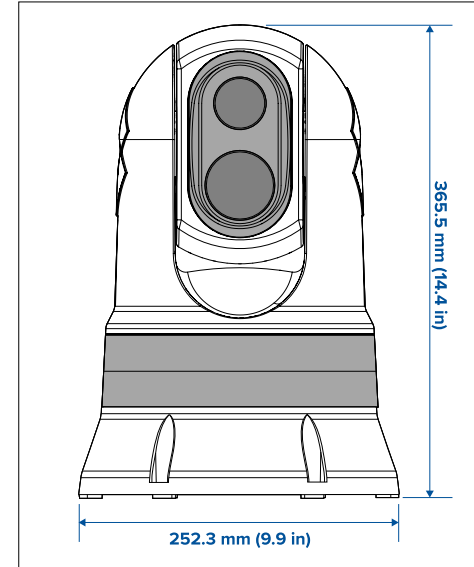

Note: Base diameter with riser base-seal fitted is 254 mm (10 in).

JCU-2 (available separately)

Product dimensions

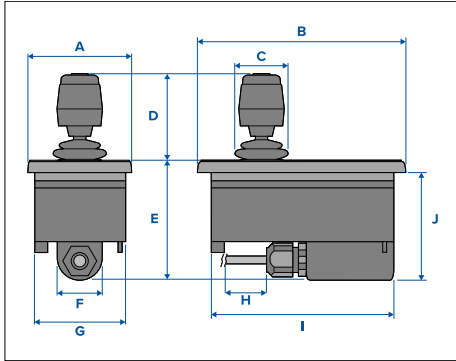

Dimension	Measurement
A	90.8 mm (3.57 in.)
B	142.8 mm (5.62 in.)
C	48.9 mm (1.93 in.)
D	75.8 mm (2.98 in.)
E	88.7 mm (3.49 in.)
F	37.9 mm (1.49 in.)
G	77.5 mm (3.05 in.)
H	7.6 mm (0.25 in.)
I	128.5 mm (5.06 in.)
J	77.0 mm (3.03 in.)

3.4 Camera orientation

The camera can be mounted in 2 orientations informally known as “Ball up” and “Ball down”.

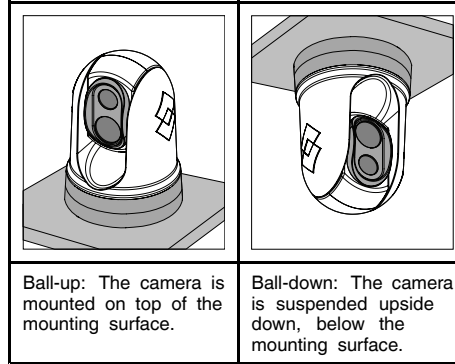

Ball-up: The camera is mounted on top of the mounting surface.

Ball-down: The camera is suspended upside down, below the mounting surface.

The default video image orientation is for the ball-up configuration; if the camera is to be mounted in the ball-down configuration then the video image must be rotated. To rotate the video image, you must either:

- use the camera’s web browser user interface to set the appropriate option (see [Web interface operation](#), page 47), or
- if your system includes a Raymarine multifunction display (MFD), use the MFD’s Camera app to set the appropriate option (refer to your [MFD Operation Instructions](#)).

3.5 Camera mounting

Location requirements

When planning the installation location, consider the following points:

- The camera is waterproof, and appropriate for above decks mounting.
- When mounting the camera in a ball-down position, ensure that the camera is installed with adequate drainage so that standing water does not collect in the base.
- Ensure the camera is installed in a location that will allow it to be accessed for regular periodic cleaning (fresh-water rinse), inspection of mounting point integrity and mechanical soundness, and preventative maintenance.
- The underside (inside) of the compartment or deck on to which the camera is mounted must be weather-tight. You must ensure protection from water ingress to cables and connections.
- The mounting surface must be horizontal.
- If you cannot access both sides of the mounting surface, then you will need to mount the camera “top down” using the mounting riser supplied with the camera.
- The camera should be mounted as high as practical, but without interfering with any radar, navigational or communications electronics.
- Choose a location that will provide the most unobstructed view in all directions.
- Choose a location as close to the vessel’s center line as possible. This provides a symmetrical view when looking forward or aft.
- Select a location for the camera that is at least 1 m (39.4 in.) from any magnetic compass.
- Select a location that is at least 1 m (3 ft) from devices that may cause interference, such as motors, generators and radio transmitters / receivers.

- If installing an optional JCU, select a location for the JCU that is at least 1 m (39.4 in.) from any magnetic compass.

Note: If you want to make cable connections to the camera before mounting it to your vessel (for example, to test the camera), first attach the three threaded studs to the base (see [Mounting the camera, page 23](#)). This will help to protect the cable connectors on the base of the camera, and also provides a stable platform, helping to prevent damage caused by the unit rolling off the edge of the work surface.

Mounting the camera

Use these instructions to mount the camera unit in position.

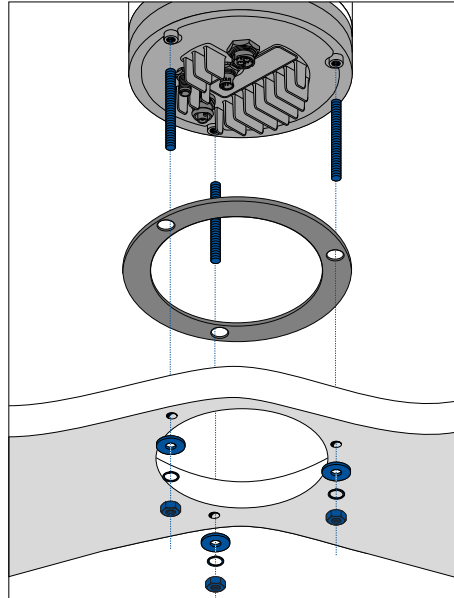

1. Using the template supplied, mark and drill the holes for mounting the camera.

Mounting holes care points:

- Check the dimensions of any printed template (to ensure that the template is printed to the correct scale) prior to drilling any holes.
- Note the area at the front of the camera, and make sure the template is oriented properly relative to the bow of the vessel. This is affected by whether the camera is to be mounted ball-up or ball-down.

2. Install the 3x threaded studs into the base of the camera with thread-locking compound. If required, you can use studs of a different length to suit your installation.
3. Slide the foam gasket over the threaded studs, and stick it firmly into place on the camera's base.
4. Connect the power supply cable, BNC video cable and network cables to the camera, and thread the cables through the central hole.
5. Place the camera on the mounting surface so the threaded studs extend through the drilled holes.
6. Make the required connections with the free ends of the cables.
7. Slide a flat washer, and then a spring washer, onto each stud.
8. Secure the camera body to the mounting surface with the supplied nuts, ensuring that the seal remains correctly positioned on the camera's base.

Tighten the nuts to a torque of 5.0 N-m (3.7 lbf-ft).

Dome capped nuts are provided for a neater solution where the mounting is exposed to view.

Mounting the camera with the optional mounting riser

The optional mounting riser is used when access to the underside of the mounting surface is restricted. Use the instructions below to mount the camera unit using the mounting riser.

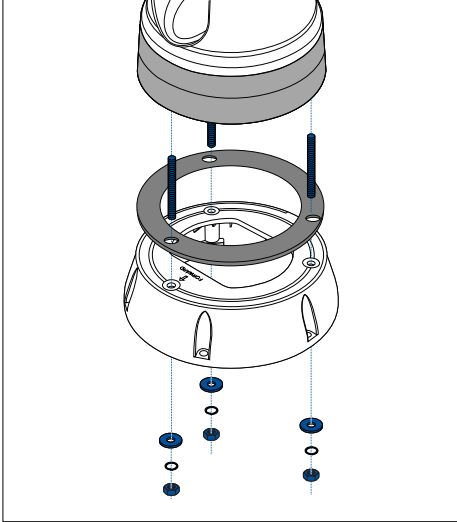

1. Using the template provided, mark and drill the holes for mounting the riser.

- Note the camera forward marking on the top surface of the riser. You must ensure that the riser is mounted so that the camera is oriented properly relative to the bow of the vessel.
- Only drill the optional cable routing hole in the mounting surface if you intend to route the cables through the base of the riser, rather than through the side of the riser.

2. Install the 3x threaded studs into the base of the camera. Do not use thread locking compound, as this may damage the plastic riser.

3. Slide the foam gasket over the threaded studs, and push it firmly into place on the camera's base.
4. Place the camera on top of the riser, so the threaded studs extend through the three holes in the riser's top surface. Check that the foam gasket remains firmly in place.

- Note the camera forward marking on the top surface of the riser. You must ensure that the riser is mounted so that the camera is oriented properly relative to the bow of the vessel.

5. Place the rubber base seal on the bottom of the riser.
6. Slide a flat washer, and then a spring washer, onto each stud.
7. Secure the camera body to the riser with the supplied nuts, ensuring that the seal remains correctly positioned on the camera's base.

Tighten the nuts to a torque of 3.7 N-m (2.7 lbf-ft).

8. Connect the power supply cable, BNC cable and network cable to the camera, then loop the cables round within the riser base so that they can be threaded through the bottom of the riser, and into the cable routing hole drilled in the mounting surface.
9. Ensure the riser-base seal is positioned correctly, and then fasten the camera-riser assembly to the mounting surface using fasteners appropriate for the surface's thickness and material. Do not use thread locking compound, as this may damage the plastic riser.

You must ensure a watertight seal between the riser base and the mounting surface. You may use a marine-grade sealant as an alternative to the supplied mounting gasket.

Note:

- If it is not possible to route the camera cables through the mounting surface, cut a hole in the side of the riser, and route the cables through the riser sidewall. You may need to loop the cables around within the riser base, so that they can be passed through the hole you have cut in the side of the riser.
- If routing the camera cables through the riser sidewall, and the camera is mounted ball-up, do NOT seal the riser base with either the supplied gasket, or sealant. Sealing may result in water pooling inside the riser.
- If routing the camera cables through the riser sidewall, and the camera is mounted ball-down, do NOT seal the connection between the camera base and the top surface of the riser with the supplied gasket. Sealing may result in water pooling inside the riser.

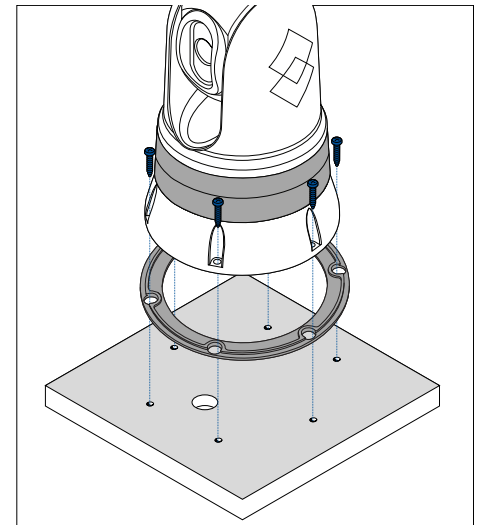

3.6 JCU-2 Mounting

Note:

The JCU-2 joystick control unit is available as an optional accessory (500-0398-10).

Location requirements

When planning the installation location, consider the following points:

- Select a position on your vessel that is close to a display showing the camera video output.
- Ensure the unit is mounted at least 1 m (39.4") away from any equipment fitted with a magnetic compass.
- The unit can be mounted to a dash or other surface in any orientation.
- Consider cable lengths and cable routing.

Removing the keypad mat

To gain access to the mounting hole locations, the keypad mat must be removed.

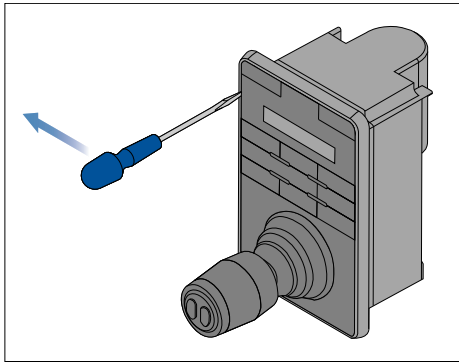

Tip To help prevent scratching the product, cover the tip of your screwdriver blade with a small piece of insulation tape.

1. Using a thin, flat bladed screwdriver insert the tip of the screwdriver into the gap between the edge of the keypad mat and the keypad housing.
2. Gently lever the keypad mat away from the keypad to release the keypad mat.

Take care not to bend the keypad mat during removal.

Flush mounting the keypad

Flush mounting provides a sleek installation where the product and dash are flush, with only the buttons and Rotary controller protruding from the dash. Flush mounting requires the mounting surface to be rebated.

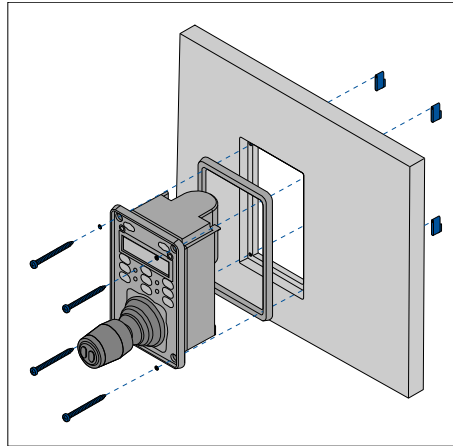

1. Check the selected location for the unit. A clear, flat area with suitable clearance behind the panel is required.
2. Before modifying the mounting surface, refer to the dimensions supplied in this document to ensure there is enough space for the unit and all cables.

3. Fix the supplied mounting template to the selected location, using masking or self adhesive tape.
4. Drill 4 holes as indicated on the mounting template to accept the fixings.
5. Using a suitable hole saw (the size and position is indicated on the template), make a hole in each corner of the cut-out area.
6. Using a suitable saw, cut along the inside edge of the cut-out line.
7. Using a Router, follow the Flush mount rebate line, to cut out a rebate to the specified rebate depth, as indicated on the template.
8. Ensure that the unit fits into the removed area and then remove rough edges.
9. Place the supplied gasket onto the rear of the keypad, ensuring the mounting holes are aligned.
10. Connect the relevant cables to the unit.
11. Place the keypad into the rebate and secure using the fixings provided.

Note: The appropriate tightening torque and drill bit size to use depends on the thickness of the mounting surface and the type of material it is made from.

Note: The supplied gasket provides a seal between the unit and a suitably flat and stiff mounting surface or binnacle. The gasket should be used in all installations. It may also be necessary to use a marine-grade sealant if the mounting surface or binnacle is not entirely flat and stiff or has a rough surface finish.

Surface mounting the keypad

Surface mounting provides a uniform installation where the products protrude, usually by the thickness of the bezel, from the mounting surface.

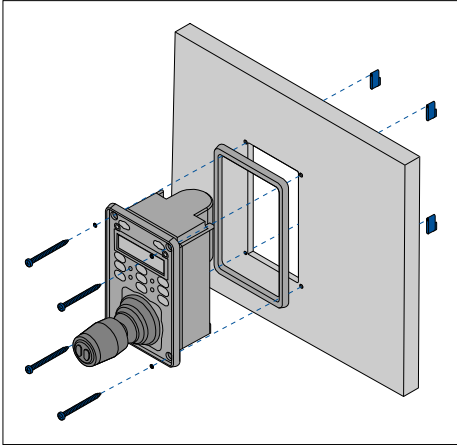

1. Check the selected location for the unit. A clear, flat area with suitable clearance behind the panel is required.
2. Before modifying the mounting surface, refer to the dimensions supplied in this document to ensure there is enough space for the unit and all cables.
3. Fix the supplied mounting template to the selected location, using masking or self adhesive tape.
4. Drill 4 holes as indicated on the mounting template to accept the fixings.
5. Using a suitable hole saw, make a hole in each corner of the cut-out area.
6. Using a suitable saw, cut along the inside edge of the cut-out line.
7. Ensure that the unit fits into the removed area and then remove rough edges.

8. Place the supplied gasket onto the rear of the keypad, ensuring the mounting holes are aligned.
9. Connect the relevant cables to the unit.
10. Secure using the fixings provided.

Note: The appropriate tightening torque and drill bit size to use depends on the thickness of the mounting surface and the type of material it is made from.

Note: The supplied gasket provides a seal between the unit and a suitably flat and stiff mounting surface or binnacle. The gasket should be used in all installations. It may also be necessary to use a marine-grade sealant if the mounting surface or binnacle is not entirely flat and stiff or has a rough surface finish.

Fitting the keypad mat

You should fit the keypad mat after the unit has been secured to the mounting surface.

1. Ensure the keypad mat is orientated correctly.
2. Slide the keypad mat over the joystick and click it into place, starting with one of the longer edges.

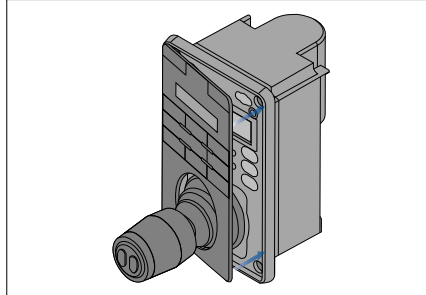

3. Close the opposite end of the keypad mat into the keypad, ensuring that the tab slides into the notch provided. Push all of the tabs on the longer sides into their notches (you should hear a click as each tab engages).

Chapter 4: Connections

Chapter contents

- [4.1 General cabling guidance on page 28](#)
- [4.2 Connections overview on page 29](#)
- [4.3 Video connections on page 30](#)
- [4.4 NMEA 0183 connection on page 32](#)
- [4.5 Typical systems on page 33](#)
- [4.6 Network connections on page 33](#)
- [4.7 Power connection on page 37](#)

4.1 General cabling guidance

Cable types and length

It is important to use cables of the appropriate type and length

- Unless otherwise stated use only standard cables of the correct type, supplied by FLIR.
- Ensure that any non-FLIR cables are of the correct quality and gauge. For example, longer power cable runs may require larger wire gauges to minimize voltage drop along the run.

Cable routing

Cables must be routed correctly, to maximize performance and prolong cable life.

- Do NOT bend cables excessively. Wherever possible, ensure a minimum bend diameter (\emptyset) of 200 mm (7.87 in) / minimum bend radius (R) of 100 mm (3.94 in).

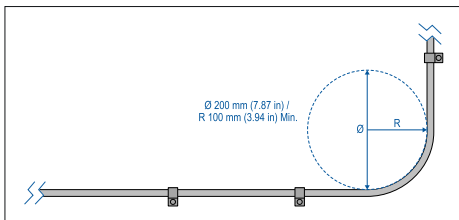

- Protect all cables from physical damage and exposure to heat. Use trunking or conduit where possible. Do NOT run cables through bilges or doorways, or close to moving or hot objects.
- Secure cables in place using cable clips or cable ties. Coil any excess cable and tie it out of the way.
- Where a cable passes through an exposed bulkhead or deckhead, use a suitable watertight feed-through.

- Do NOT run cables near to engines or fluorescent lights.
- Always route data cables as far away as possible from:
 - other equipment and cables,
 - high current carrying AC and DC power lines,
 - antennas.

Strain relief

Use adequate strain relief for cabling to ensure that connectors are protected from strain and will not pull out under extreme sea conditions.

Circuit isolation

Appropriate circuit isolation is required for installations using both AC and DC current:

- Always use isolating transformers or a separate power-inverter to run PC's, processors, displays and other sensitive electronic instruments or devices.
- Always use an isolating transformer with Weather FAX audio cables.
- Always use an isolated power supply when using a 3rd party audio amplifier.
- Always use an RS232/NMEA converter with optical isolation on the signal lines.
- Always make sure that PC's or other sensitive electronic devices have a dedicated power circuit.

Cable shielding

Ensure that cable shielding is not damaged during installation and that all cables are properly shielded.

HD-SDI cable connection

When making the HD-SDI connection to the camera using the supplied cable, ensure that the rubber shroud surrounding the cable connector is secured

with cable ties (not supplied), once fitted to the connector. Fit one tie to the shroud at the point where the cable enters the bottom of the shroud, and another tie around the shroud where it covers the connector itself.

4.2 Connections overview

Your product includes the following connectors

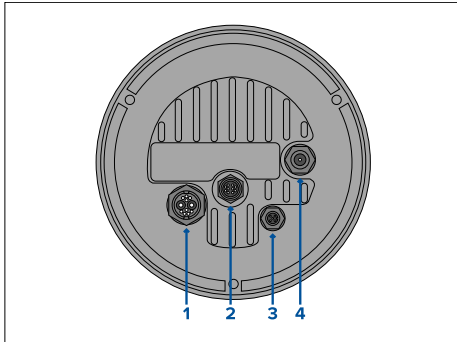

Connector	Connects to	Suitable cables
1) Power / NMEA 0183 / Composite video	<ul style="list-style-type: none"> • 12 / 24 V dc power supply • NMEA 0183 in / out • Composite video (on female BNC connector) 	<ul style="list-style-type: none"> • Right-angled power supply cable (supplied)
	<p>Note: The NMEA 0183 wires are not currently active, and will be supported in a future software update.</p>	
2) RayNet	<ul style="list-style-type: none"> • RayNet network device 	<ul style="list-style-type: none"> • RayNet-to-RJ45 adapter cable (supplied) • Right-angled RayNet-to-RayNet cable (supplied)

Connector	Connects to	Suitable cables
3) DeviceNet	<ul style="list-style-type: none"> • DeviceNet network device / backbone • SeaTalkng network device / backbone 	<ul style="list-style-type: none"> • DeviceNet-to-DeviceNet cable • DeviceNet-to-SeaTalkng adapter cable
	<p>Note: The DeviceNet connector is not currently active, and will be supported in a future software update.</p>	
4) HD SDI	<ul style="list-style-type: none"> • HD-SDI digital video device, or HDMI via suitable converter and cables, available separately from third-party retailers. 	<ul style="list-style-type: none"> • HD-SDI video cable (supplied), terminated in BNC connectors.

For more information on available cables refer to [Chapter 12 Spares and Accessories](#)

Note: The cables should be routed to a dry area of the vessel for connection. Alternatively you must ensure that all connections are water tight.

Note: If you want to make cable connections to the camera before mounting it to your vessel (for example, to test the camera), first attach the 3 threaded studs to the base. This will help to protect the cable connectors on the base of the camera, and also provides a stable platform, helping to prevent damage caused by the unit rolling off the edge of the work surface.

Connecting cables

Follow the steps below to connect the cable(s) to your product.

1. Ensure that the vessel's power supply is switched off.
2. Ensure that the device being connected has been installed in accordance with the installation instructions supplied with that device.
3. Ensuring correct orientation, push cable connectors fully onto the corresponding connectors.
4. If applicable, engage any locking mechanism to ensure a secure connection.
5. Ensure any bare ended wire connections are suitably insulated to prevent corrosion due to water ingress.

Orientation of right-angled connectors

When making connections using the supplied right-angled power and network cables, ensure that you orient the connectors correctly with respect to the thermal camera base.

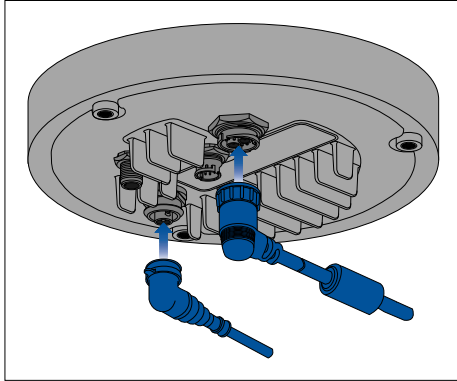

4.3 Video connections

The camera's video output can be distributed to up to 4 devices, simultaneously.

Furthermore, with the dual payload camera variants you can use any of the 4 different camera video outputs to display different **combinations** of thermal and visible light video feed, simultaneously. For example, you can view the thermal video feed via the HD-SDI video output, and the visible light video feed at the same time via a laptop connected to the camera's RayNet (Ethernet) connector.

Note: There is also a specific scenario where it is possible to distribute video to more than 4 devices simultaneously. With a Raymarine Axiom Pro multifunction display (MFD), you can connect the camera's **analog** composite video **output** to the MFD's **analog** composite video **input**, and then share/repeat that video feed in realtime over the RayNet network to multiple additional LightHouse 3 Raymarine MFDs on the same network. This can all be output simultaneously with the 3 other digital video outputs described below.

The 4 different video outputs are:

- 2x **digital** video outputs via the RayNet (Ethernet / IP) connector, streamed over Ethernet/IP:
 - **H264-encoded digital video** — this is streamed to an ONVIF (Profile S)-compatible IP video-capable display, video distribution unit, video multiplexer, or Raymarine LightHouse 3 multifunction display (MFD).
 - **MPEG-encoded digital video** — this is streamed to a web browser on a PC / laptop / tablet connected to the camera's RayNet (Ethernet) connector.
- 1x **digital** video feed, output via the HD-SDI connector.
- 1x **analog** video feed, output via the composite video BNC connector on the camera's power cable.

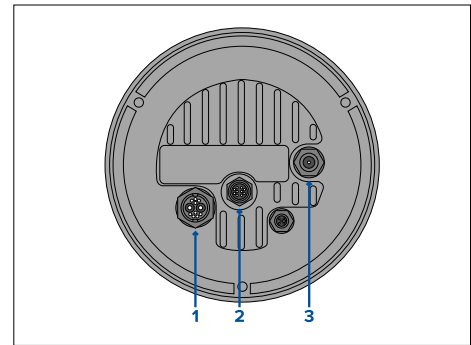

	Connector	Video format
1	Composite video BNC connector on camera's power cable	Analog video.
2	RayNet (Ethernet)	<ul style="list-style-type: none"> • H264-encoded IP digital video (ONVIF Profile S). • MPEG-encoded IP digital video (via web browser only).
3	HD-SDI	Digital video, HD-SDI format (SMPTE-292M).

Note: It is also possible to connect to an HDMI-capable display or other video device, via a suitable third-party HD-SDI to HDMI converter. Contact your dealer or retailer for suitable devices and cables.

Note: ONVIF profiles help you to determine which IP digital video devices are compatible with one another. For more information on ONVIF profiles, refer to: www.onvif.org/profiles/

Switching between thermal and visible light (daylight) camera feeds (dual payload camera variants only)

The dual payload camera variants have separate thermal and visible light (daylight) video feeds, and you can switch between these 2 different video feeds at any time using a JCU, a web browser, or a Raymarine LightHouse 3 MFD.

Video and network cables

A range of cables is supplied with the camera to cover typical connection scenarios. You may need to purchase additional cables to complete your installation.

Connector	Suitable cables
Composite video BNC connector on camera's power cable	Use the supplied BNC-to-BNC video cable (3 m / 9.8 ft.), if not using otherwise for the HD-SDI connection. Alternatively, obtain a 75-ohm coax video cable terminated in BNC connectors at both ends. (The BNC connector on the camera's power cable is a female connector).
RayNet (Ethernet)	To connect to a device with an RJ45 socket: Use the supplied RayNet-to-RJ45 adapter cable (120 mm / 4.7 in.). Longer adapter cables are available separately — refer to 12.2 RayNet to RJ45 adapter cables To connect to a Raymarine MFD or RayNet network switch: Obtain a suitable length RayNet-to-RayNet cable (available separately — refer to 12.3 RayNet to RayNet cables and connectors).
HD-SDI	Use the supplied BNC-to-BNC video cable (3 m / 9.8 ft.). If a longer cable is required, obtain a 75-ohm coax video cable terminated in BNC connectors at both ends. (The BNC connector on the camera is a female connector).

Note: It is also possible to connect to an HDMI-capable display or other video device, via a suitable third-party HD-SDI to HDMI converter. Contact your dealer or retailer for suitable devices and cables.

4.4 NMEA 0183 connection

NMEA 0183 devices can be connected to your camera using the NMEA 0183 wires on the supplied Power/Video/NMEA 0183 cable.

2 NMEA 0183 ports are available:

- **Port 1:** Input and output: 4,800 baud rate only.
- **Port 2:** Input only: 4,800 baud rate only.

Note:

- For Port 1, both the input and output communicate at the same baud rate. For example, if you have one NMEA 0183 device connected to Port 1 INPUT, and another NMEA 0183 device connected to Port 1 OUTPUT, both NMEA devices must use the same baud rate.

Up to 4 devices can be connected to the camera's output port, and up to 2 devices to the camera's input ports.

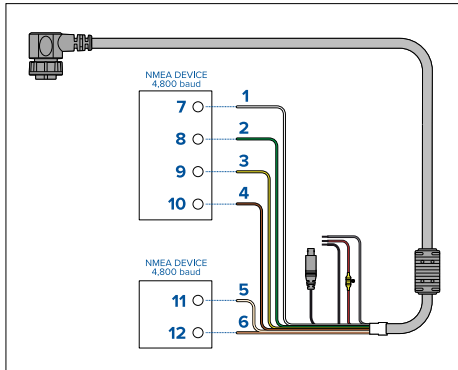

Item	Device	Cable color	Port	In-put / out-put	Positive (+) / Negative (-)
1	Camera	White	1	Input	Positive
2		Green	1	Input	Negative
3		Yellow	1	Output	Positive
4		Brown	1	Output	Negative
5		Orange / White	2	Input	Positive
6		Orange / Green	2	Input	Negative
7	NMEA device	*	*	Output	Positive
8		*	*	Output	Negative
9		*	*	Input	Positive
10		*	*	Input	Negative
11	NMEA device	*	*	Output	Positive
12		*	*	Output	Negative

Note:

* Refer to instructions provided with your NMEA 0183 device for connection details.

4.5 Typical systems

The camera can be connected to a variety of digital or analog video systems, and controlled via a JCU, a web browser, a Raymarine multifunction display (MFD), or any combination of these.

Note:

- For information on how to connect the product, refer to the [Connections overview, page 29](#)
 - For information on available cables and accessories, refer to the [Spares and accessories, page 69](#)
- **Basic Web browser system:** You can connect the camera directly to an IP-capable device, such as a laptop or PC, using the supplied RayNet cable and RayNet-to-RJ45 adapter cable. You can control the camera through the user interface, accessible via a web browser.
 - **Basic digital video display system with JCU:** You can connect the camera directly to a primary digital video display via the camera's HD-SDI output and the supplied BNC cable, or via HDMI using a suitable third-party video converter (available separately from an electronics retail outlet).
 - **Basic analog video display system with JCU:** You can connect the camera directly to a primary analog video display via the camera's composite analog video output using the BNC connector on the camera's power cable.
 - **Basic Web browser system with JCU:** You can connect the product to an IP-capable device, such as a laptop or PC, via an Ethernet switch (using the supplied RayNet cable and RayNet-to-RJ45 adapter cable), and an additional Ethernet cable. You can control the camera through the user interface accessible via a web browser, or with a JCU unit, also connected to the Ethernet switch.
 - **Basic Raymarine LightHouse 3 multifunction display (MFD) system:** You can connect the product directly to a Raymarine LightHouse 3

MFD using the supplied RayNet cable. You can control the camera directly using the MFD. For a more flexible system, you can install a RayNet switch between the camera and the MFD, and add a JCU unit (also connected to the RayNet switch) to provide additional camera controls.

- **Complex system with multiple cameras, MFDs, and JCUs:** With sufficient RayNet or Ethernet ports available on installed switches, and appropriate RayNet and Ethernet cables, you can connect multiple cameras, MFDs, and JCUs together to form an integrated system. You can use any JCU or MFD to control and monitor any camera.

4.6 Network connections

Your camera has a single RayNet network connector. This connects the camera to your vessel's wider IP network. This could be an existing third-party Ethernet network, or a dedicated Raymarine RayNet network.

The details of the network connections between the camera, video display (web browser, video monitor, or LightHouse 3 Raymarine multifunction display), control unit (for example, a JCU-2 controller) and the rest of your installation depend on:

- How you want to control the camera (for example, with a web browser, a LightHouse 3 Raymarine multifunction display, a JCU controller, or a combination).
- How you want to view the camera's IP video feed (for example, via a laptop / PC or via a LightHouse 3 Raymarine multifunction display, or a combination).
- the equipment already installed on your vessel (for example, network switches with free ports, or other cameras).

The following sections show some possible network connections, starting with a basic system with a single camera directly connected to web browser, and finishing with a more complex multi-camera, multi-display, multi-JCU system.

Non-RayNet systems

You can install your camera on a vessel that doesn't have a RayNet network or LightHouse 3 Raymarine multifunction display (MFD) installed.

The following examples show possible network connections for:

- A single-camera system with the camera connected directly to a laptop or other device running a web browser (for camera control, and viewing the camera's IP video feed).
- A single-camera system comprising a laptop or other device running a web browser (for camera control, and viewing the camera's IP video feed), an Ethernet network switch with PoE, and an

optional JCU (available separately) for additional camera control

- A single-camera system comprising a digital video monitor connected via the camera's HD-SDI video feed, an Ethernet network switch with PoE, and a JCU (available separately) for camera control.
- A single-camera system comprising a digital video monitor connected via the camera's HD-SDI video feed and an HDMI converter to allow connection via HDMI. Also an Ethernet network switch with PoE, and a JCU (available separately) for camera control.
- A single-camera system comprising an analog video monitor connected via the camera's composite video feed (connected via the power cable), an Ethernet network switch with PoE, and a JCU (available separately) for camera control.

Single-camera system with direct connection to web browser

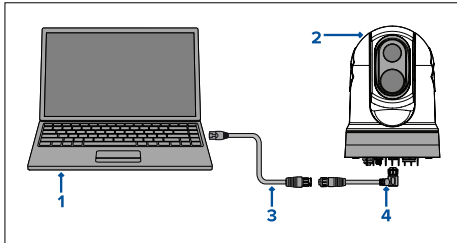

Note: Power connections are not shown in this illustration. The camera and the other devices shown require their own dedicated power connection.

	Description
1	Laptop (or other Ethernet-connected device running a web browser), available separately from third-party retailers
2	M300 Series camera

	Description
3	RayNet-to-RJ45 adapter cable (120 mm / 4.7 in.) (supplied with camera)
4	Right angled RayNet-to-RayNet cable (3 m / 9.8 ft) (supplied with camera)

Single-camera system with web browser and an optional JCU

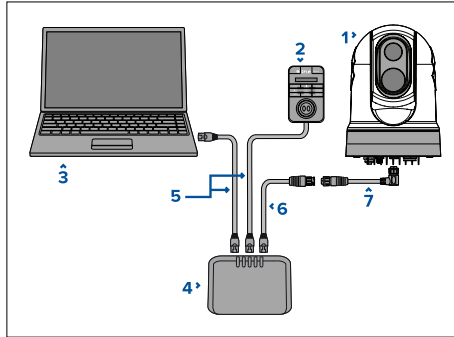

Note: Power connections are not shown in this illustration. The camera and the other devices shown require their own dedicated power connection.

	Description
1	M300 Series camera
2	Joystick control unit (JCU-2), available separately
3	Laptop (or other Ethernet-connected device running a web browser)
4	Ethernet network switch with PoE
5	RJ45-to-RJ45 Ethernet cable

	Description
6	RayNet-to-RJ45 adapter cable (120 mm / 4.7 in.) (supplied with camera)
7	Right angled RayNet-to-RayNet cable (3 m / 9.8 ft) (supplied with camera)

Single-camera system with digital video (HD-SDI) monitor and JCU

For this system, a device running a web browser is not required. The camera's video feed is routed through the camera's HD-SDI video connection to a digital video monitor. Camera control is provided by a JCU (available separately).

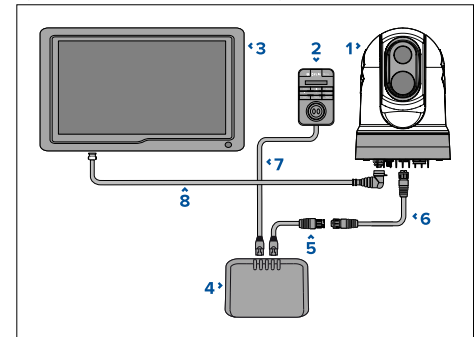

Note: Power connections are not shown in this illustration. The camera and the other devices shown require their own dedicated power connection.

	Description
1	M300 Series camera
2	Joystick control unit (JCU-2), available separately
3	Digital video (HD-SDI) monitor, available separately from third-party retailers

	Description
4	Ethernet network switch with PoE, available separately
5	RayNet-to-RJ45 adapter cable (120 mm / 4.7 in.) (supplied with camera)
6	RayNet-to-RayNet cable, available separately
7	RJ45-to-RJ45 cable, available separately
8	HD-SDI video cable (BNC connectors) (3 m / 9.8 ft.) (supplied with camera)

Single-camera system with digital video (HDMI) monitor and JCU

For this system, a device running a web browser is not required. The camera's video feed is routed through the camera's HD-SDI video connection via a third-party HD-SDI to HDMI video converter (not supplied) to a digital video monitor. Camera control is provided by a JCU (available separately).

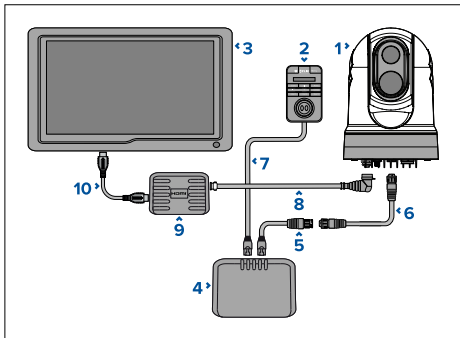

Note: Power connections are not shown in this illustration. The camera and the other devices shown require their own dedicated power connection.

	Description
1	M300 Series camera
2	Joystick control unit (JCU-2), available separately
3	Digital video (HD-SDI) monitor, available separately from third-party retailers
4	Ethernet network switch with PoE, available separately
5	RayNet-to-RJ45 adapter cable (120 mm / 4.7 in.) (supplied with camera)
6	RayNet-to-RayNet cable, available separately
7	RJ45-to-RJ45 cable, available separately
8	HD-SDI video cable (BNC connectors) (3 m / 9.8 ft.) (supplied with camera)
9	HD-SDI to HDMI video converter, available separately from third-party retailers
10	HDMI cable, available separately from third-party retailers

Single-camera system with analog video monitor and JCU

For this system, a device running a web browser is not required. The camera's video feed is routed through the power cable's composite analog video connection to an analog video monitor. Camera control is provided by a JCU (available separately).

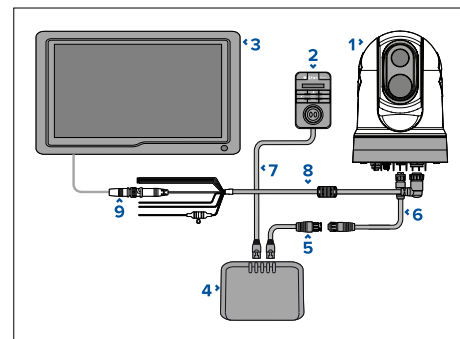

Note: Power connections are not shown in this illustration. The camera and the other devices shown require their own dedicated power connection.

	Description
1	M300 Series camera
2	Joystick control unit (JCU-2), available separately
3	Analog video monitor, available separately from third-party retailers
4	Ethernet network switch with PoE, available separately
5	RayNet-to-RJ45 adapter cable (120 mm / 4.7 in.) (supplied with camera)
6	RayNet-to-RayNet cable, available separately
7	RJ45-to-RJ45 cable, available separately

	Description
8	Camera's power cable (3 m / 9.8 ft.) (supplied with camera)
9	BNC-to-BNC video cable. If you are not using the supplied BNC cable (3 m / 9.8 ft.) for the HD-SDI connection, you can use it for this composite analog connection. Otherwise, obtain a suitable cable, separately from third-party retailers.

RayNet systems with Raymarine LightHouse 3 multifunction displays (MFDs)

M300 Series cameras are compatible with Raymarine LightHouse 3 multifunction displays (MFDs) and existing RayNet networks.

The following examples show possible network connections for:

- a single-camera system comprising a Raymarine LightHouse 3 MFD (for camera control, and viewing the camera's IP video feed), a RayNet network switch, a JCU (available separately) for additional camera control, and a Power over Ethernet (PoE) Injector.
- a multi-camera system comprising an HD-SDI video monitor connected, 2 Raymarine MFDs (available separately), a RayNet network switch (available separately), 2 JCUs (available separately), a Power over Ethernet (PoE) Injector (available separately), and a web browser (laptop) (available separately) for additional camera control.

Single-camera system with Raymarine MFD and JCU

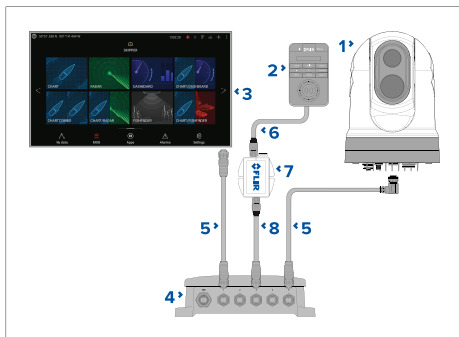

Note: Power connections are not shown in this illustration. The camera and the other devices shown require their own dedicated power connection.

	Description
1	M300 Series camera
2	Joystick control unit (JCU-2), available separately
3	Raymarine MFD, available separately
4	RayNet network switch, available separately
5	Right-angled RayNet-to-RayNet cable, (supplied with camera)
6	RJ45-to-RJ45 cable, available separately

	Description
7	PoE injector (provides power to JCU-2), available separately
8	RayNet-to-RJ45 adapter cable, (120 mm / 4.7 in. version supplied with camera; other lengths available separately)

Multi-camera system with digital video monitor, 2 Raymarine MFDs, 2 JCUs, and a web browser

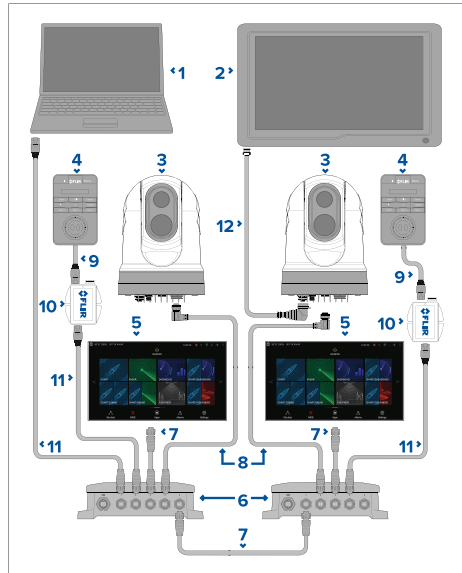

Note: Power connections are not shown in this illustration. The camera and the other devices shown require their own dedicated power connection.

	Description
1	Laptop (or other Ethernet-connected device running a web browser), available separately from third-party retailers
2	Digital video monitor, available separately from third-party retailers
3	M300 Series camera
4	Joystick control unit (JCU-2), available separately
5	Raymarine MFD, available separately
6	RayNet network switch, available separately
7	RayNet-to-RayNet cable, available separately
8	Right angled RayNet-to-RayNet cable (3 m / 9.8 ft) (supplied with camera)
9	RJ45-to-RJ45 cable, available separately
10	PoE injector (provides power to JCU-2), available separately
11	RayNet-to-RJ45 adapter cable, (120 mm / 4.72 in. version supplied with camera; other lengths available separately)
12	HD-SDI video cable (BNC connectors) (3 m / 9.8 ft.) (supplied with camera)

4.7 Power connection

Power must be supplied to the camera from an appropriate power source.

Power connection requirements

- 12 or 24 Vdc nominal supply voltage
- Isolated power supply
- Connected via an appropriately-rated thermal breaker or fused switch (refer to *Inline fuse and thermal breaker ratings*).

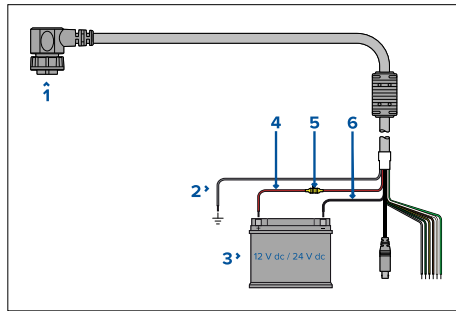

	Description	Connects to:
1	Power cable.	Product's power connector.
2	Drain / ground (thin black wire)	Vessel's RF ground, or negative battery terminal.
3	Connection to 12 V / 24 V power supply.	Vessel's power supply.
4	Red cable (positive)	Power supply's positive terminal

	Description	Connects to:
5	Inline fuse	Waterproof fuse holder containing a suitably-rated inline fuse (refer to <i>Inline fuse and thermal breaker ratings</i>).
6	Black cable (thick black wire) (negative)	Power supply's negative terminal

Power distribution

Recommendations and best practice.

- The product is supplied with a power cable, either as a separate item or a captive cable permanently attached to the product. Only use the power cable supplied with the product. Do NOT use a power cable designed for, or supplied with, a different product.
- Refer to the *Power connection* section for more information on how to identify the wires in your product's power cable, and where to connect them.
- See below for more information on implementation for some common power distribution scenarios:

Important:

- When planning and wiring, take into consideration other products in your system, some of which (e.g. sonar modules) may place large power demand peaks on the vessel's electrical system, which may impact the voltage available to other products during the peaks.
- The information provided below is for guidance only, to help protect your product. It covers common vessel power arrangements, but does NOT cover every scenario. If you are unsure how to provide the correct level of protection, please consult an authorized dealer or a suitably qualified professional marine electrician.

Implementation — connection to distribution panel (Recommended)

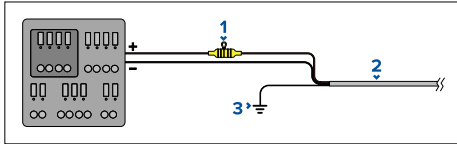

1	Waterproof fuse holder containing a suitably-rated inline fuse must be fitted. For suitable fuse rating, refer to: <i>In-line fuse and thermal breaker ratings</i> .
2	Product power cable.
3	Drain wire connection point.

- It is recommended that the supplied power cable is connected to a suitable breaker or switch on the vessel's distribution panel or factory-fitted power distribution point.
- The distribution point should be fed from the vessel's primary power source by 8 AWG (8.36 mm²) cable.
- Ideally, all equipment should be wired to individual suitably-rated thermal breakers or fuses, with appropriate circuit protection. Where this is not possible and more than 1 item of equipment shares a breaker, use individual in-line fuses for each power circuit to provide the necessary protection.

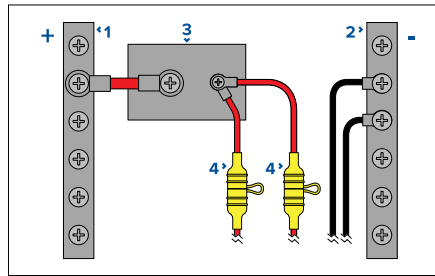

1	Positive (+) bar
2	Negative (-) bar
3	Circuit breaker
4	Waterproof fuse holder containing a suitably-rated inline fuse must be fitted. For suitable fuse rating, refer to: <i>In-line fuse and thermal breaker ratings</i> .

Important:

Observe the recommended fuse / breaker ratings provided in the product's documentation, however be aware that the suitable fuse / breaker rating is dependent on the number of devices being connected.

Implementation — direct connection to battery

- Where connection to a power distribution panel is not possible, the power cable supplied with your product may be connected directly to the vessel's battery, via a suitably rated fuse or breaker.
- The power cable supplied with your product may NOT include a separate drain wire. If this is the case, only the power cable's red and black wires need to be connected.
- If the power cable is NOT supplied with a fitted inline fuse, you MUST fit a suitably rated fuse or

breaker between the red wire and the battery's positive terminal.

- Refer to the inline fuse ratings provided in the product's documentation.
- If you need to extend the length of the power cable supplied with your product, ensure you observe the dedicated *Power cable extensions* advice provided in the product's documentation.

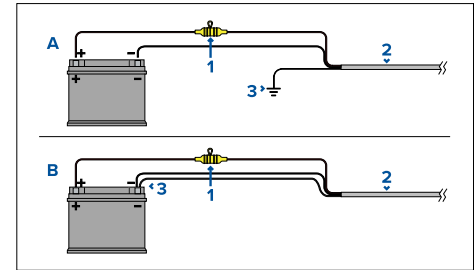

1	Waterproof fuse holder containing a suitably-rated inline fuse must be fitted. For suitable fuse rating, refer to: <i>In-line fuse and thermal breaker ratings</i> .
2	Product power cable.
3	Drain wire connection point.

Battery connection scenario A:

Suitable for a vessel with a common RF ground point. In this scenario, if your product's power cable is supplied with a separate drain wire then it should be connected to the vessel's common ground point.

Battery connection scenario B:

Suitable for a vessel without a common grounding point. In this case, if your product's power cable is supplied with a separate drain wire then it should be connected directly to the battery's negative terminal.

Power cable extension

If you need to extend the length of the power cable supplied with your product, ensure you observe the following advice:

- The power cable for each unit in your system should be run as a separate, single length of 2-wire cable from the unit to the vessel's battery or distribution panel.
- Ensure that the extension cable is of a sufficient gauge for the supply voltage and the total load of the device and the length of the cable run. Refer to the following table for typical **minimum** power cable wire gauges.

Cable length in meters (feet)	Wire gauge in AWG (mm ²) for 12 V supply	Wire gauge in AWG (mm ²) for 24 V supply
<8 (<25)	16 (1.31 mm ²)	18 (0.82 mm ²)
16 (50)	14 (2.08 mm ²)	18 (0.82 mm ²)
24 (75)	12 (3.31 mm ²)	16 (1.31 mm ²)
>32 (>100)	10 (5.26 mm ²)	16 (1.31 mm ²)

Important:

Be aware that some products in your system (such as sonar modules) can create voltage peaks at certain times, which may impact the voltage available to other products during the peaks.

Important: To ensure power cables (including any extension) are of a sufficient gauge, ensure that there is a continuous **minimum** voltage of **10.8 V dc** at the end of the cable where it enters the product's power connector, even with a fully flat battery at 11 V dc. (Do not assume that a flat battery is at 0 V dc. Due to the discharge profile and internal chemistry of batteries, the current drops much faster than the voltage. A "fully flat" battery still shows a positive voltage, even if it doesn't have enough current to power your device.)

Grounding

Ensure that you observe any additional grounding advice provided in the product's documentation.

More information

It is recommended that best practice is observed in all vessel electrical installations, as detailed in the following standards:

- BMEA Code of Practice for Electrical and Electronic Installations in Boats
- NMEA 0400 Installation Standard
- ABYC E-11 AC & DC Electrical Systems on Boats
- ABYC A-31 Battery chargers and Inverters
- ABYC TE-4 Lightning Protection

In-line fuse and thermal breaker ratings

The following in-line fuse and thermal breaker ratings apply to your product:

In-line fuse rating	Thermal breaker rating
15 A slow blow	15 A (if only connecting one device)

Note:

- The suitable fuse rating for the thermal breaker is dependent on the number of devices you are connecting. If in doubt consult an authorized FLIR dealer.
- Your product's power cable may have a fitted in-line fuse, if not then you can add an in-line fuse to the positive wire of your product's power connection.

Grounding — Dedicated drain wire

The power cable supplied with this product includes a dedicated shield (drain) wire for connection to a vessel's RF ground point.

It is important that an effective RF ground is connected to the system. A single ground point should be used for all equipment. The unit can be grounded by connecting the shield (drain) wire of the power cable to the vessel's RF ground point. On vessels without an RF ground system the shield (drain) wire should be connected directly to the negative battery terminal.

The dc power system should be either:

- Negative grounded, with the negative battery terminal connected to the vessel's ground.
- Floating, with neither battery terminal connected to the vessel's ground



Warning: Positive ground systems

Do not connect this unit to a system which has positive grounding.

Chapter 5: Camera control options and status icons

Chapter contents

- [5.1 Camera control options on page 42](#)
- [5.2 Camera image on page 42](#)
- [5.3 Camera control on page 45](#)

5.1 Camera control options

There are a number of different ways of controlling the camera remotely.

- **Via a web browser** — With the camera connected to a laptop or tablet via Ethernet, you can use the camera's web browser to view and control the camera remotely.
- **Via a JCU** — With the JCU connected to the camera via a network switch, you can use the JCU's physical controls to control the camera remotely.
- **Via a Raymarine LightHouse 3 MFD** — With the camera connected to the MFD or the MFD's network via RayNet (Ethernet), you can use the MFD's Video app to view and control the camera remotely.

Note: It is also possible to switch the thermal / visible light video feed of dual payload camera variants using any of the control options listed above.

5.2 Camera image

The M300 camera outputs an IP digital video feed which can be displayed on a video monitor, a web browser, or a Raymarine LightHouse 3 multifunction display (MFD).

Depending on chosen camera model, the IP digital video feed comprises:

- Visible light (daylight) image
- Thermal image
- Status icons overlaid on the video image

Thermal Camera

You should take time to familiarize yourself with the thermal image. This will help you to make the most of your system:

You should take time to familiarize yourself with the thermal image. This will help you to make the most of your system:

- Consider every object you view in terms of how it will look "thermally" as opposed to how it looks to your eye. For example look for changes caused by the heating effect of the sun. These are particularly evident right after sunset.
- Experiment with different palettes and scene presets.
- Experiment by looking for hot objects (such as people) compared to the colder surroundings.
- Experiment with the camera for daytime viewing. The camera can provide improved daytime viewing in environments where traditional video camera performance suffers, such as in shadows or backlit scenes.







Camera status icons





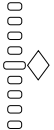
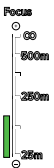

The camera image includes icons to show the current status of the camera.





Note:

Icons are colored red if the **WhiteHot** or **BlackHot** palette is in use, and colored white for all other palettes.

Icon	Name	Description
	Thermal Camera	Indicates the Thermal Camera feed is active.
	Visible / Daylight Camera	Indicates the Visible / Daylight Camera feed is active.

Icon	Name	Description
	Azimuth (Position)	Shows the azimuth (or direction) of the camera relative to the vessel. The triangle shows the approximate camera field of view (FOV).
	Elevation (Tilt)	Shows the vertical tilt of the camera. The triangle shows the approximate camera position.
	Focus Scale	Shown when autofocus is invoked to indicate the progress of the operation.
	Home	Indicates the camera is in the home position; the icon flashes when a new home position is set.
	Lock Zoom	Lock the zoom of camera to the active payload, whenever possible.
	Mirrored View	Indicates the camera feed is reversed against the vertical axis.

Icon	Name	Description
	Polarity	Indicates a change in image polarity.
	Color Palette	Indicates a change in image color palette.
	NMEA BWS Message	Receiving NMEA messages using Bearing and Distance to Waypoint, Great Circle (BWC) sentence format has been enabled; this is also known as slew to waypoint.
	NMEA RSD	Receiving NMEA messages using the Radar System Data (RSD) sentence format has been enabled; this is also known as radar cursor tracking.
	NMEA TTM	Receiving NMEA messages using the NMEA Tracked Target Message (TTM) sentence format has been enabled; this is also known as radar tracking.
	Power Down	The camera is shutting down.

Icon	Name	Description
	Scene: Night	One of four scene presents (automatic gain control settings) optimized for use on the open water at night.
	Scene: Docking	One of four scene presents (automatic gain control settings) optimized for use when the boat is docking at night.
	Scene: Day	One of four scene presents (automatic gain control settings) optimized for use on the open water during the day.
	Scene: Contrast	One of four scene presents (automatic gain control settings) optimized for providing visibility to small moving objects.
	Vertical Stabilization	Indicates the gyro stabilization setting is verticle only (point mode), which improves camera image stability while keeping the camera pointing in the same position relative to the vessel as it turns.

Icon	Name	Description
	Vertical and Horizontal Stabilization	Indicates the gyro stabilization setting, which improves camera image stability, while keeping the camera pointing in the same direction even as the vessel turns.
	Zoom Scale	Shown to indicate the progress of the zoom position of the active camera.

Image adjustments

Thermal camera scene presets

Scene presets enable you to quickly select the best image setting for the current environmental conditions.

During normal operation the thermal camera automatically adjusts itself to provide a high-contrast image optimized for most conditions. The Scene presets provide 4 additional settings that may provide better imagery in certain conditions. The 4 modes are:

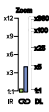
- **Day** — scene preset mode for daytime conditions.
- **Night** — scene preset mode for night conditions.
- **Docking** — scene preset mode for docking.
- **High Contrast** — scene preset mode for extra-high contrast.

Although the preset names indicate their intended use, varying environmental conditions might make another setting more preferable. For example, the night running scene preset might also be useful while in a harbor. You may find it beneficial to experiment with the different scene presets to discover the best preset to use for different conditions.

Thermal camera color modes

A range of color modes are available to help you distinguish objects on-screen in different conditions.

Changing the color mode switches the thermal camera image between four available color palettes:

- WhiteHot
- RedHot
- Fusion
- Firelce

The factory default color mode is WhiteHot, which may improve your night vision.

Thermal camera reverse video

You can reverse the polarity of the video image to change the appearance of objects on-screen.

Changing the polarity setting will toggle between the two available polarities for the color mode that is already selected.

The available polarity options are:

- WhiteHot / BlackHot
- RedHot / RedHot Inverse
- Fusion / Fusion Inverse
- Firelce / Firelce Inverse

You may find it useful to experiment with this option to find the best setting to suit your needs.

Ball-down mode

You can configure the camera to account for a unit that is installed “ball down” (that is, with the base fixings positioned *above* the camera lens). For ball-down installations, the image presented on displays is rotated 180 degrees, and pan and tilt controls are modified to account for the inverted camera.

Ball down mode can be configured by accessing the camera’s Web interface, for more information refer to [Web interface operation](#) , page 47

Thermal camera

Set ball-down mode for the thermal camera.

From the camera’s web interface:

1. Select the **Thermal** menu on the left of the screen.
The **Thermal** menu is open.
2. Scroll down to **Mirroring / Inversion** and select the drop down menu.
The drop down menu is open.
3. From the list select the desired mirroring / inversion you want to apply to your camera feed:
 - Ball down Off / Rearview Off — the camera feed is not inverted or mirrored (use when camera is mounted ball-up and facing forward)
 - Ball down On / Rearview Off — the camera feed is inverted (use when the camera is mounted ball-down and facing forward)
 - Ball down Off / Rearview On — the camera feed is mirrored (use when the camera is mounted ball-up and facing aft)
 - Ball down On / Rearview On — the camera feed is inverted and mirrored (use when the camera is ball-down and facing aft)

Note:

To change the controls of the camera for use in ball-down mode refer to the PTZ (Pan Tilt Zoom) settings menu.

Visible camera

Set ball-down mode for the visible camera.

From the camera’s web interface:

1. Select the **Visible** menu on the left of the screen.
The **Visible** menu is open.
2. Scroll to the **E-flip** and **Reverse** toggle buttons.
3. From the list select the desired mirroring / inversion you want to apply to your camera feed:
 - E-flip Off / Reverse Off — the camera feed is not inverted or mirrored (use when camera is mounted ball-up and facing forward)

- E-flip On / Reverse Off — the camera feed is inverted (use when the camera is mounted ball-down and facing forward)
- E-flip Off / Reverse On — the camera feed is mirrored (use when the camera is mounted ball-up and facing aft)
- E-flip On / Reverse On — the camera feed is inverted and mirrored (use when the camera is ball-down and facing aft)

Note:
To change the controls of the camera for use in ball-down mode refer to the PTZ (Pan Tilt Zoom) settings menu.

5.3 Camera control

Pan, tilt and zoom

The camera controls allow for pan (azimuth) and tilt (elevation) of the camera, as well as zoom (magnification) of the thermal image.

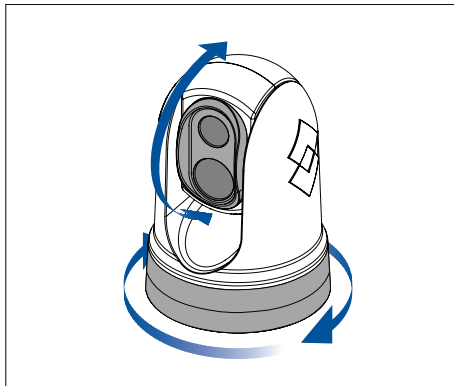

- Pan continuously through 360°.
- Tilt to +110°/-90° relative to the camera base.
- Zoom the thermal camera image.

You can control pan, tilt, and zoom, using:

- the camera's web browser interface: see [Web interface operation](#), page 47
- the Joystick on a JCU remote keypad: see [JCU-2 controls overview](#), page 54
- the touchscreen of a compatible Raymarine MFD: see the "Video app" section in the documentation supplied with your MFD.

Home position

The home position is a preset position for the camera.

The home position usually defines a useful reference point — for example, straight ahead and level with the horizon.

	<ul style="list-style-type: none"> • The home icon is displayed momentarily when you command the camera to move to its home position. • The home icon flashes 3 times when you set the camera's home position.
---	--

You can set the home position as required, and return the camera to the home position, using:

- the camera's web browser interface: see [Web interface operation](#), page 47
- a JCU remote keypad: see [JCU-2 controls overview](#), page 54
- a compatible Raymarine MFD: see the "Video app" application section in the documentation supplied with your MFD.

Surveillance mode

In surveillance mode the camera continuously pans left and right, automatically scanning the scene.

The camera continues scanning until you:

- disable surveillance mode
- manually pan or tilt the camera
- command the camera to move to its home position

Any of these actions stops surveillance mode; surveillance mode does not resume until you re-enable it.

You can control surveillance mode, including the scan speed and scan width, using:

- the camera's web browser interface: see [Web interface operation](#), page 47

- the user programmable buttons on a JCU remote keypad: see [Configuring JCU-2 user-programmable buttons \(UPBs\)](#), page 55
- a compatible Raymarine MFD: see the “Video app” section in the documentation supplied with your MFD.

Chapter 6: Web interface operation

Chapter contents

- 6.1 Web browser user interface overview on page 48
- 6.2 Setting up a network connection to the camera on page 48
- 6.3 Logging in to the Web browser user interface on page 49
- 6.4 Video feed on page 50
- 6.5 Camera settings menus on page 50
- 6.6 System settings on page 50
- 6.7 Troubleshoot on page 51

6.1 Web browser user interface overview

This chapter describes how to use a Web browser to communicate with and configure your M300 Series camera.

M300 Series cameras are network devices that communicate over an Ethernet network using Internet Protocol (IP). Using a Web browser, you can view video, control the camera, and change camera configuration settings.

Note: Changes to configuration settings should only be made by someone who has expertise with M300 Series cameras and a thorough understanding of how the settings affect the image. Haphazard changes can lead to image problems including a complete loss of video.

You can use various types of IP-networked device to interact with the camera's Web interface (such as a laptop, PC, tablet, or smart phone). The device must be connected to the same network as the camera (or connected directly), and running a supported Web browser (Microsoft Internet Explorer version 9 or later, or the latest version of the Google Chrome, Microsoft Edge, or Mozilla Firefox browsers).

Note:

- To communicate with and configure your M300 Series camera using a JCU-2 control unit, refer to [JCU-2 operation](#), page 53
- To communicate with and configure your M300 camera using a Raymarine LightHouse 3 multifunction display (MFD), refer to [MFD operation](#), page 57

6.2 Setting up a network connection to the camera

Your camera supports DHCP and UPnP to simplify the process of finding the camera on a network, and connecting to it using a web browser.

Note: The web browser must be running on a device that is on the same network as the camera.

DHCP (Dynamic Host Control Protocol) is used to automatically assign IP addresses and other important IP-network parameters to devices on a network. The camera is set to use DHCP by default.

UPnP (Universal Plug and Play) is a protocol that helps the camera identify itself to other network devices.

Note: You should not attempt to set the camera's IP-network parameters manually unless you have previous experience with configuring IP networks.

To set up a network connection between your IP device (such as a laptop or PC), and the camera:

1.
 - If your system already includes a network switch (either a 3rd-party switch, or a Raymarine HS5 switch, for example), connect both the camera and the IP device that will run your web browser, to the switch (see [Non-RayNet systems, page 33](#) for example network connections). Then power-on the camera, network switch, and IP device.
 - If you don't have any existing networking hardware (such as a network switch), connect the camera and IP device together directly (see [Non-RayNet systems, page 33](#) for example network connections). Then power-on the camera, and IP device.
2. Make sure that your IP device is:
 - a. *configured to obtain an IP address automatically.* For Windows 7, 8, and 10:
 - i. Go to **Control Panel**, then **Network and Sharing Center** > **Change adapter settings**.
 - ii. Right-click the network connection corresponding to the wired Ethernet connection on your IP device (often labelled "Local Area Connection") and select **Properties**
 - iii. Select the **Networking** tab.
 - iv. Under **This connection uses the following items**, select **Internet Protocol Version 4 (TCP/IPv4)**.
 - v. Select **Properties**.
 - vi. Check that the option to **Obtain an IP address automatically** is selected.
 - b. *configured to detect UPnP devices.* For Windows 7, 8, and 10:
 - i. Go to **Control Panel** > **Network and Sharing Center** > **Advanced sharing settings**
 - ii. Check that the option to **Turn on network discovery** is selected.
3. The camera is automatically added to the list of devices located by your IP device, and is named according to the camera part number, and serial number (for example: *E70353 1234*). For Windows 7, 8, and 10, the camera is listed in Windows Explorer under **Network**.

Note: Depending on your network configuration, it may take up to five minutes for the camera to appear in the list of devices. If the camera is not listed after five minutes, double-check that your IP address is configured as described in step 2, then try renewing your IP device's IP address. For Windows 7, 8, and 10:

- a. Go to **Start > Run**, then type "cmd" (without quotes), and click **OK**.
- b. In the Command Prompt window that opens, type "ipconfig /release" (without quotes), then press Enter.
- c. Type "ipconfig /renew" (without quotes), then press Enter.
- d. Type "exit" (without quotes), then press Enter to close the window.

4. Under **Network**, double-click the camera item to open the camera's web page. To show more information about the camera, including its IP address, right-click the camera item and select **Properties**.

6.3 Logging in to the Web browser user interface

You can log in to the camera's Web interface using one of three User Names: **user**, **expert**, or **admin**. By default, the passwords are: **user**, **expert**, and **admin**, respectively.

- The **user** login can access the Live Video page and control the camera.
- The **expert** login can access the Setup menus and make configuration changes to the payloads and other components.
- The **admin** login can access the Maintenance menu and all the other menus as well as change the login passwords.

You should change the default login passwords to prevent unauthorized log in.

Note: Only two web sessions can be active at once.

To log in:

1. Go to the camera's web page by:
 - entering the camera's IP address directly into the address bar of your web browser, OR
 - double-clicking the camera in "My Network Places" (Windows XP) or "Network" (later versions of Windows).

(See [Setting up a network connection to the camera](#), page 48 for more information.)

The login screen is displayed:

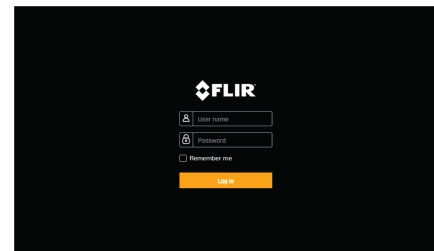

2. Enter **user** for User Name and **user** for Password, then click Log in.

First time login

After successfully logging into the web interface for the first time, you will be prompted to enter a new secure password for future use.

<p>New Password must:</p> <ul style="list-style-type: none">• Contain 12 characters• Contain at least 1 lower-case character• Contain at least 1 upper-case character	<p>Change Password</p> <p>Password <input type="password"/></p> <p>Confirm password <input type="password"/></p> <p><input type="button" value="Save"/></p>
--	---

6.4 Video feed

After logging in you can view the live image from the camera's current video stream.

Settings

From the top right menu you can:

- change between the visible and thermal streams using the V and T icons.
- set the Live Video Refresh Rate
- Change camera movement control setting:
- **Joystick** — pressing and holding an edge of the video stream will pan/tilt the camera in that direction continuously until released.
- **Cross** — pressing anywhere on the video stream will pan/tilt the camera so the location pressed become the new centre of the stream.



6.5 Camera settings menus

You can access different camera settings menus on the left side of the video stream. The settings contained in these menu pages can be used to configure your camera.

- **Video** — Edit general video settings.
- **Visible** — Edit the visible camera settings.
- **Thermal** — Edit the thermal camera settings.
- **PTZ (Pan Tilt Zoom)** — Edit the Pan Tilt and Zoom settings and control the camera.
- **Video Analytics** — Edit MVA (Marine Video Analytics) and object detection settings.
- **OSD (On Screen Display)** — Edit the on-screen status symbols and icons displayed on the video feed.

6.6 System settings

You can access advanced camera settings and diagnostic information by selecting **System Settings** at the bottom of the screen.

- Network
- Date & Time
- Users
- JCU
- Temperature
- Cyber
- ONVIF
- Firmware & info

6.7 Troubleshoot

Setting a static IP address

In some circumstances, you may need to set a static IP address for the camera's IP-network, rather than relying on the automatic IP addresses provided by the DHCP service (the camera's default setting).

Note: Unless you are specifically instructed in FLIR documentation, or have previous experience of configuring IP networks, you should NOT attempt to set the camera's IP-network parameters manually. If you mis-configure the IP-network parameters, your camera may stop working correctly or become inaccessible on the network.

This procedure assumes that you have already established a network connection, and can access the camera's Web interface (see). To configure the camera's IP network parameters manually:

1. In the Internet Explorer Browser, type the camera IP address into the address bar.

The camera's web interface is displayed

2. In the **User Name** box, type "expert"; in the **Password** box, type "expert", then click **Log in**.

The **Live Video** page is displayed.

3. In the top menu, click **Configuration**, then in the left-hand menu, click **Server > LAN Settings**.

The camera's network options are displayed.



4. Make any required changes to the IP-network parameters ("LAN Settings"). The following example shows how to set a static IP address:
 - i. In the **Interface: eth0** section of the page, from the **IP Address Mode** list, select **Static**.
 - ii. Adjust the values for **IP Address** and **Netmask** as required for the network your

camera will be connected to. The remaining parameters are not likely to require changes.

Note: Keep a record of the address shown in the **IP Address** box below the **IP Address Mode** list. You will need this address to access the camera's configuration web interface in future.

5. At the bottom of the LAN Settings page, click **Save**.

An information dialog confirms that settings have been changed, and that a network restart is required.

6. click **Restart Network**.

An information dialog confirms that the network has restarted, and that you may need to enter a new IP address to regain access to the camera's Web interface.

Chapter 7: JCU-2 operation

Chapter contents

- 7.1 Main Menu on page 54
- 7.2 JCU-2 controls overview on page 54

7.1 Main Menu

You can access and control the camera's **Main Menu** via a connected JCU-2. The menu will be overlaid on the video feed.

- Use the Menu button on the JCU-2 to turn the OSD (on screen display) Main Menu on or off.
- The Joystick can be used to navigate through the menus.
- Press the right Joystick button to select each menu.
- Press the left Joystick button to exit the menu.

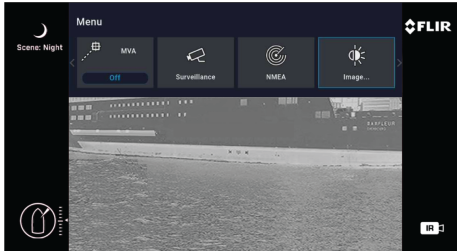

Main Menu Items

- **Park Camera** — the camera will pan and tilt to its predefined Park position. The park position can be edited from the Web interface, see [Web interface operation](#), page 47
- **MVA** — access MVA (Marine Video Analytics) settings.
- **Surveillance** — the camera will enter surveillance mode, it pans continuously left and right until it is taken out of surveillance mode or until the JCU moves the camera.
- **NMEA** — enable or disable the processing of messages using the NMEA interface.
- **Image** — access advanced image settings.
- **Settings** — access advanced camera settings.
- **Help** — opens the help menu.

7.2 JCU-2 controls overview

The camera can be controlled with a JCU-2.

Note:

- The JCU-2 joystick control unit is available separately as an optional accessory.
- For more information on other compatible JCU units refer to [Compatible joystick controllers \(JCU\)](#), page 18

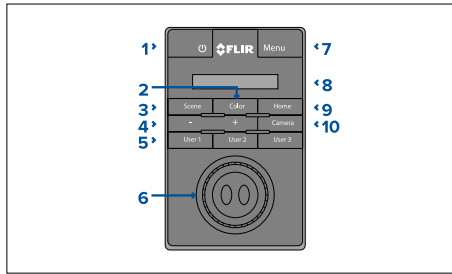

1	POWER <ul style="list-style-type: none"> • Press cycle JCU-2 display brightness Dim > Normal > Bright. • Press and hold to wake camera or enter power menu.
2	COLOR <ul style="list-style-type: none"> • Press to change palette. • Press and hold to change polarity.

3	SCENE <ul style="list-style-type: none"> • Press to change scene settings.
4	MANUAL FOCUS <ul style="list-style-type: none"> • + Press to focus farther away. • - Press to focus closer.
5	USER 1, USER 2, USER 3 <ul style="list-style-type: none"> • User programmable buttons (configured via camera web page: see Configuring JCU-2 user-programmable buttons (UPBs), page 55). Default action is "toggle rear-view mirror mode".

6	<p>JOYSTICK To Manage Camera</p> <ul style="list-style-type: none"> • Twist to zoom camera. • Push fore / aft to tilt camera. • Push left or right to rotate camera. <p>To Navigate On-Screen Menus</p> <ul style="list-style-type: none"> • Push left / right / up /down to highlight menu item. • Push right joystick button to select menu item. • Push left / right to change numeric value. • Push right joystick button to toggle switch. • Push left joystick button to exit current menu item. <p>To Navigate JCU LCD Menu</p> <ul style="list-style-type: none"> • Push fore / aft to scroll up / down. • Push left joystick button to select menu item.
---	--

7	<p>MENU</p> <ul style="list-style-type: none"> • Press to enable on-screen menu. • Press to exit menu.
8	<p>LCD DISPLAY</p> <ul style="list-style-type: none"> • Displays JCU information and power menu options. • Use joystick to interact.
9	<p>HOME</p> <ul style="list-style-type: none"> • Press to return to home position. • Press and hold until home icon flashes to store new home.
10	<p>CAMERA</p> <ul style="list-style-type: none"> • Press to select active camera.

Configuring JCU-2 user-programmable buttons (UPBs)

Note: The JCU-2 joystick control unit is available separately as an optional accessory.

The JCU-2 keypad's user-programmable buttons (UPBs) can be configured using the camera's Web interface. For more information on accessing the Web interface refer to [Web interface operation](#), page 47

You can assign a different action to each UPB (for example, "Vertical stabilization", or "Surveillance mode") on a per-camera basis.

Note: UPB mappings apply to individual cameras rather than to specific JCU-2 keypads. This means that, if you are using a single JCU-2 keypad to control two M300 Series cameras, UPB number 1 could be configured to initiate a different action on each camera.

To configure JCU-2 user programmable buttons (UPBs) using the camera's Web interface:

1. From the camera's Web interface, select **System Settings** at the bottom left of the menu.
The Settings menus are displayed.
2. From the menus at the top select **JCU**.
The **JCU** setting page is displayed.

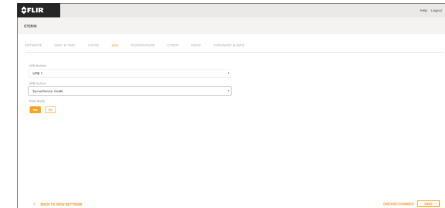

3. From the **UPB Button** list, select the button you wish to configure.
4. From the **UPB Action** list, choose the camera action you wish to associate with that UPB button.
5. Repeat steps 3 and 4 for each UPB you wish to configure.
6. Select **Save** to save the UPB Configuration.

Chapter 8: MFD operation

Chapter contents

- [8.1 Overview on page 58](#)
- [8.2 ClearCruise thermal analytics on page 58](#)
- [8.3 Auto-tracking on page 58](#)

8.1 Overview

Your camera can be controlled using a Raymarine™ Lighthouse 3 Multifunction Display.

For more information refer to your MFD manual, <http://www.raymarine.co.uk/manuals-documents/>

8.2 ClearCruise thermal analytics

ClearCruise™ intelligent thermal analytics technology provides audible and visual alerts when “non-water” objects are identified in the scene.

Boats, obstacles, and navigation markers can all be automatically identified in a scene by ClearCruise™.



You can activate ClearCruise™ and control “beep on detection”, using a compatible Raymarine MFD: see the “Camera” application section in the documentation supplied with your MFD.

Note: To use ClearCruise™, your system must include a compatible Raymarine® MFD running LightHouse™ 3 software.

Note: ClearCruise™ detection performance is dependent on conditions, and is not a replacement for maintaining a visual watch.

Important: ClearCruise™ Object Detection is only compatible with cameras that are positioned upright. ClearCruise™ Object Detection will not function with cameras that are upside down or have vertical flip enabled.

8.3 Auto-tracking

You can set the camera to automatically track the following targets:

- man overboard
- dangerous AIS target
- dangerous MARPA target

You can activate auto-tracking, and control which types of target are tracked, using a compatible Raymarine MFD: see the “Video app” section in the documentation supplied with your MFD.

Note: To use auto-tracking, your system must include a compatible Raymarine MFD.

Chapter 9: Maintenance

Chapter contents

- 9.1 Service and maintenance on page 60
- 9.2 Cleaning the camera on page 60

9.1 Service and maintenance

This product contains no user serviceable components. Please refer all maintenance and repair to authorized FLIR dealers. Unauthorized repair may affect your warranty.

9.2 Cleaning the camera

The camera housing and lens will require occasional cleaning. You should clean the lens when image quality degradation is noticed or excessive contaminant buildup is seen. Clean the interface between the yoke and base often to prevent accumulation of debris or salt deposits.

When cleaning this product:

- Do NOT wipe the lens window with a dry cloth, or with abrasive materials such as paper or scrub brushes, as this could scratch the coating.
- Do NOT use acid or ammonia based products.
- Do NOT pressure wash.

Particular care should be taken when cleaning the lens window, this has a protective anti-reflective coating which may be damaged by improper cleaning.

1. Switch off the power to the unit.
2. Clean the camera body with a clean, soft cotton cloth. You can moisten the cloth and use a mild detergent if required.
3. Clean the camera lens.
 - Rinse the lens with fresh water to remove all dirt particles and salt deposits, and allow to dry naturally.
 - If any spots or smears remain, very gently wipe the lens window with a clean microfibre cloth or soft cotton cloth.
 - If necessary, use isopropyl alcohol (IPA) or a mild detergent to remove any remaining spots or marks.

Chapter 10: System checks and troubleshooting

Chapter contents

- [10.1 Thermal camera troubleshooting on page 62](#)
- [10.2 FLIR Maritime product support and servicing on page 63](#)

10.1 Thermal camera troubleshooting

Problems with the thermal camera and their possible causes and solutions are described here.

Problem	Possible causes	Possible solutions
Video not displayed.	Camera is in Standby mode.	The camera will not display video if it is in Standby mode. Use the camera controls (either the thermal camera application or JCU) to “wake” the camera from standby.
	Problem with the thermal camera network connections.	<ul style="list-style-type: none"> • Check thermal camera network cables (RayNet or Ethernet) are sound and properly connected.
	Problem with power supply to the camera or JCU (if used as the primary controller)	<ul style="list-style-type: none"> • Check the power connections to the camera and JCU / PoE injector (if used). • Ensure that the power switch / breaker is on. • Check the fuse / breaker state.
Cannot control thermal camera from Raymarine display or keyboard.	Thermal camera application is not running.	Ensure the thermal camera application is running on the multifunction display (as opposed to the video application which does not have camera controls).
Erratic or unresponsive controls.	Network problem.	Check that the controller and thermal camera are correctly connected to the network. (Note: This may be a direct connection or via a Raymarine network switch.)
		Check the status of the Raymarine network switch.
		Check that SeaTalk ^{hs} / RayNet cables are free from damage.
	Control conflict, e.g. caused by multiple users at different stations.	Ensure that no other controllers are in use at the same time.
Problem with the controller.	Check power / network cabling to the controller and PoE injector (PoE only used with optional Joystick Control Unit).	
	Check other controllers if available. If other controllers are operating this will eliminate the possibility of a more fundamental camera fault.	
Image too dark or too light.	Display brightness is set too low.	Use the brightness controls at the display to adjust accordingly.
	The Scene Mode is not appropriate for the current conditions.	A particular environment may benefit from a different Scene Mode setting. For example, a very cold background (such as the sky) could cause the camera to use a wider temperature range than appropriate. Use the SCENE button.
Image is inverted (upside down).	Camera “Ball down” setting is incorrect.	Ensure that the Ball down setting is set correctly.

10.2 FLIR Maritime product support and servicing

FLIR provides a comprehensive product support service, as well as warranty, service, and repairs. You can access these services through the FLIR website, telephone, and e-mail.

Product information

If you need to request service or support, please have the following information to hand:

- Product name.
- Product identity.
- Serial number.
- Software application version.
- System diagrams.

You can obtain this product information using the menus within your product.

Servicing and warranty

FLIR offers dedicated service departments for warranty, service, and repairs.

Don't forget to visit the FLIR website to register your product for extended warranty benefits:

<http://customer.flir.com/Warranty/EndUserRegistration>.

Region	Telephone	E-mail
United Kingdom (UK), EMEA, and Asia Pacific	+44 (0)1329 246 932	emea.service@flir.com
United States (US)	+1 (603) 324 7900	rm-usrepair@flir.com

Web support

On the FLIR website, please visit the "Marine" portal support area: <http://www.flir.com/marine/support>

System checks and troubleshooting

Telephone and e-mail support

Region	Telephone	E-mail
United Kingdom (UK), EMEA, and Asia Pacific	+44 (0)1329 246 777	maritimecamerasupport@flir.com
United States (US)	+1 (603) 324 7900 (Toll-free: +800 539 5539)	support@flir.com
Australia and New Zealand	+61 2 8977 0300	aus.support@flir.com (FLIR Maritime subsidiary)
France	+33 (0)1 46 49 72 30	support.fr@flir.com (FLIR Maritime subsidiary)
Germany	+49 (0)40 237 808 0	support.de@flir.com (FLIR Maritime subsidiary)
Italy	+39 02 9945 1001	support.it@flir.com (FLIR Maritime subsidiary)
Netherlands	+31 (0)26 3614 905	support.nl@flir.com (FLIR Maritime subsidiary)

Region	Telephone	E-mail
Sweden	+46 (0)317 633 670	support.se@flir.com (FLIR Maritime subsidiary)
Finland	+358 (0)207 619 937	support.fi@flir.com (FLIR Maritime subsidiary)
Norway	+47 692 64 600	support.no@flir.com (FLIR Maritime subsidiary)
Denmark	+45 437 164 64	support.dk@flir.com (FLIR Maritime subsidiary)

Chapter 11: Technical specification

Chapter contents

- [11.1 M300 Series cameras on page 66](#)
- [11.2 JCU-2 on page 67](#)

11.1 M300 Series cameras

Technical specification

Nominal supply voltage	12 or 24 V dc
Operating voltage range	-10% to +30% of nominal supply range
Current	Peak 10.0 A
Power consumption	<ul style="list-style-type: none"> • 41 W typical • 56 W typical (with heaters on) <div style="border: 1px solid black; padding: 5px; margin-top: 10px;"> <p>Note: FLIR recommends using a 75 W power supply</p> </div>
Environmental	<ul style="list-style-type: none"> • Operating temperature: -25 °C to +55 °C (-13 °F to 131 °F) • Storage temperature: -30 °C to +70 °C (-22 °F to 158 °F) • Relative humidity: max 95% • Water ingress protection: IPx6 • Wind: 100 mph (161 kph) • Vibration: IEC 60945; MIL-STD-810E • Salt Mist: IEC60945

Electromagnetic compliance	EMI: IEC 60945
Dimensions	<p>Camera:</p> <ul style="list-style-type: none"> • Base diameter: 222.2 mm (8.7 in.) • Height: 328.3 mm (12.9 in.) <p>Camera attached to mounting riser:</p> <ul style="list-style-type: none"> • Base diameter (without seal): 252.3 mm (9.9 in.) • Base diameter (with seal): 254.0 mm (10.0 in.) • Height: 365.5 mm (14.4 in.)
Weight	6.3 kg (13.9 lb) without mounting riser; 6.75 kg (14.9 lb) with mounting riser

Pan / tilt	<ul style="list-style-type: none"> • 360° continuous pan • +110°/-90° tilt
Video	<ul style="list-style-type: none"> • IP digital video format: H264-encoded IP video stream, compatible with ONVIF Profile S • IP digital video format: MPEG-encoded IP video stream (accessible via Web interface only) • HD-SDI digital video format: SMPTE-292M • Video resolution: 640(H) x 512(V) pixels • Sensor resolution: 320(H) x 240(V) pixels • Field of view: 24 degrees (horizontal); 18 degrees (vertical)

11.2 JCU-2

Technical specification

Power specification

PoE class	Class 1
Nominal supply voltage	<ul style="list-style-type: none">• PoE: 48 V dc• Alternate power: 12 V / 24 V dc
Operating voltage range	<ul style="list-style-type: none">• PoE: 44 V to 57 V dc• Alternate power: 9 V to 32 V dc
Power consumption	4 W Max with full keypad illumination

Environmental specification

Operating temperature	-25 °C to +55 °C (-13 °F to 131 °F)
Storage temperature	-30 °C to +70 °C (-22 °F to 158 °F)
Relative humidity	Maximum 93%
Waterproof rating	IPx6 & IPx7

Wired connections

Network / PoE	1 x RJ45 Ethernet 10/100 Mb/s connector
----------------------	---

Chapter 12: Spares and accessories

Chapter contents

- [12.1 M300 Series camera spares and accessories on page 70](#)
- [12.2 RayNet to RJ45 adapter cables on page 71](#)
- [12.3 RayNet to RayNet cables and connectors on page 73](#)

12.1 M300 Series camera spares and accessories

Accessories

Item	Part number
RayNet-to-RJ45 adapter cable, 120 mm (4.7 in)	A80513
RJ45 Coupler (Waterproof Enclosure)	4115028
JCU-1 remote control unit	500-0385-00
JCU-2 remote control unit	500-0398-10
JCU-3 remote control unit (with portrait and landscape keypad mats)	A80510
Power over Ethernet (PoE) 5-port network switch	4141042
12 V Power over Ethernet (PoE) Injector	4113746

12.2 RayNet to RJ45 adapter cables

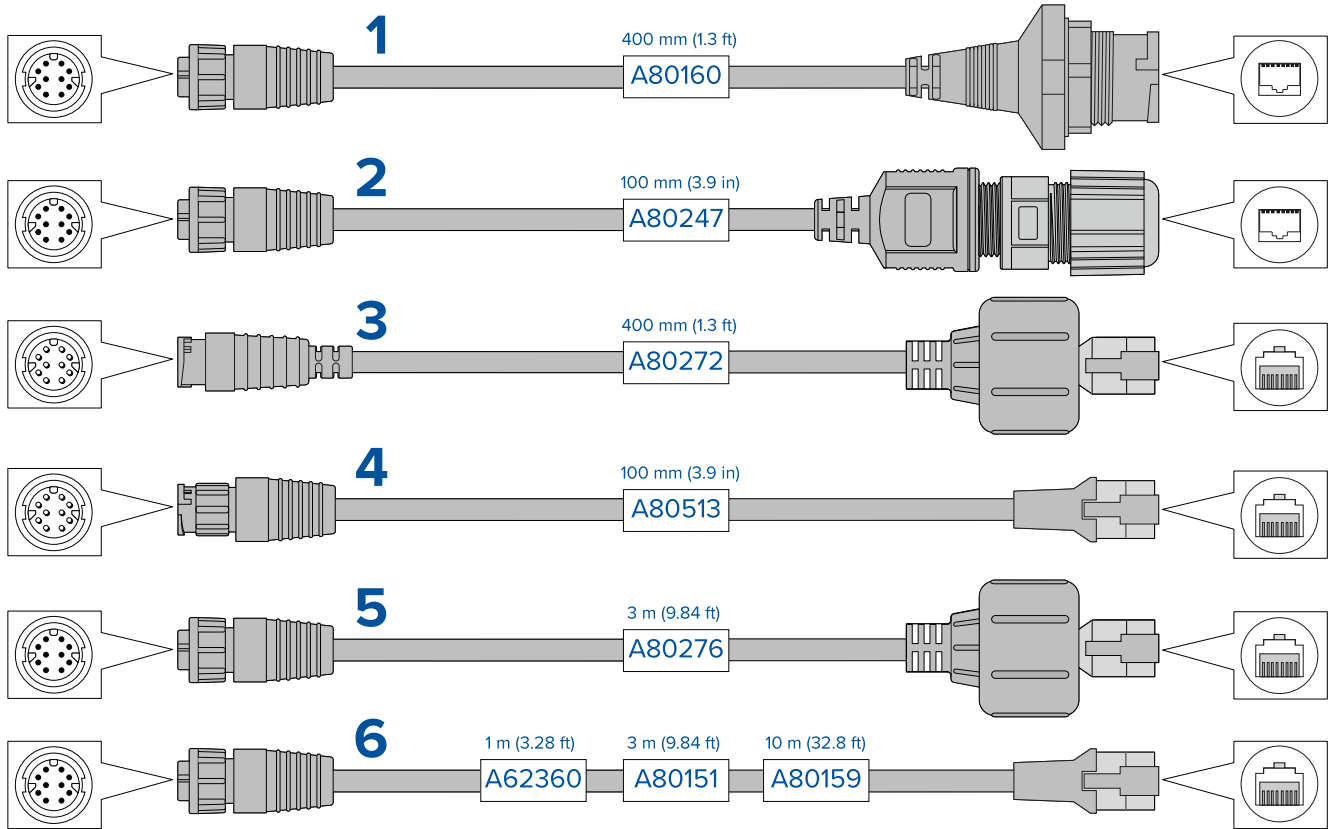

	Description
1	<p>Adapter cable with a RayNet (female) socket on one end, and a waterproof (female) socket on the other end accepting the following cables with an RJ45 SeaTalk^{hs} waterproof locking (male) plug:</p> <ul style="list-style-type: none"> • A62245 (1.5 m). • A62246 (15 m).
2	<p>Adapter cable with a RayNet (female) socket on one end, and a waterproof (female) RJ45 socket on the other end, along with a locking gland for a watertight fit.</p>
3	<p>Adapter cable with a RayNet (male) plug on one end, and an RJ45 SeaTalk^{hs} waterproof (male) plug on the other end.</p>
4	<p>Adapter cable with a RayNet (male) plug on one end, and an RJ45 SeaTalk^{hs} (male) plug on the other end.</p>
5	<p>Adapter cable with a RayNet (female) socket on one end, and an RJ45 SeaTalk^{hs} waterproof (male) plug on the other end.</p>
6	<p>Adapter cable with a RayNet (female) socket on one end, and an RJ45 SeaTalk^{hs} (male) socket on the other end.</p>

12.3 RayNet to RayNet cables and connectors

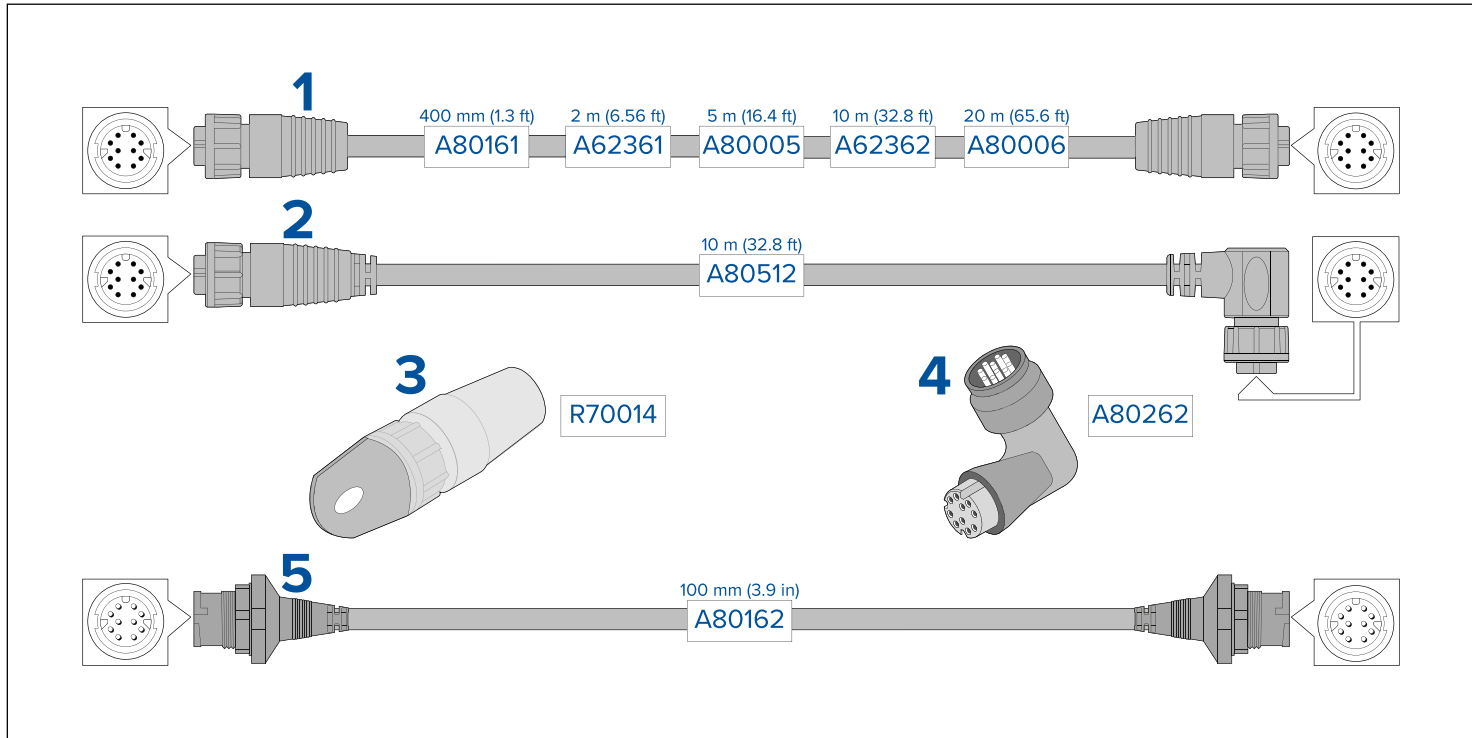

	Description
1	Standard RayNet connection cable with a RayNet (female) socket on both ends.
2	Right-angle RayNet connection cable with a straight RayNet (female) socket on one end, and a right-angle RayNet (female) socket on the other end. Suitable for connecting at 90° (right angle) to a device, for installations where space is limited.
3	RayNet cable puller (5 pack).

	Description
4	RayNet to RayNet right-angle coupler / adapter. Suitable for connecting RayNet cables at 90° (right angle) to devices, for installations where space is limited.
5	Adapter cable with a RayNet (male) plug on both ends. Suitable for joining (female) RayNet cables together for longer cable runs.

Index

A

Accessories	70
Network adapter cables.....	71
Network cables.....	73
RayNet cables.....	73
Applicable products.....	14

B

Ball-down mode	44
Box contents, <i>See</i> Parts supplied (JCU-2), <i>See</i> Parts supplied (M300)	

C

Cable	
Bend radius	28
Protection.....	28
Routing	28
Security.....	28
Strain relief.....	28
Camera control options	42
Camera image.....	42
Camera orientation	22
Ball-down	22
Ball-up	22
ClearCruise	16, 58
Color modes.....	44
Compass safe distance	20
Compatible hardware	
JCU	18
MFD	18
Connecting cables.....	30
Connection	
Power.....	37
Connections	
Battery.....	38
Distribution panel.....	38
General cabling guidance.....	28
NMEA 0183.....	32
Contact details.....	63

D

Declaration of Conformity	11
---------------------------------	----

E

Electromagnetic Compatibility	10
EMC, <i>See</i> Electromagnetic Compatibility	
Environmental specification.....	67

F

Flush mounting	25
----------------------	----

H

Home position.....	45
--------------------	----

I

Installation	
Best practice	39
Camera orientation.....	22
Dimensions	
JCU-2	22
M300	21
JCU-2.....	25
Location requirements.....	20, 22
Mounting	
JCU-2	25-26
M300	23-24
Mounting riser.....	21
Tools required	21
Interference	20
<i>See also</i> Compass safe distance	
IP address	
static.....	51

J

JCU	
JCU-1.....	18
JCU-2.....	18, 22

JCU-3.....	18
Overview.....	54
JCU-2.....	
Controls.....	54
UPBs	55

K

Keypad mat fitting.....	26
keypad mat removal.....	25

L

Location requirements.....	22
----------------------------	----

M

Maintenance	10, 60
MFD.....	
Auto-tracking	58
ClearCruise.....	58
Overview.....	58
Mounting riser.....	24

N

Network connections	15
Typical system.....	15
NMEA 0183.....	
Baud rate.....	32
NMEA 0183 connection.....	32

O

Operation.....	
Ball-down mode.....	44
Camera control options.....	42
Camera controls.....	
Home position	45
Pan, tilt, zoom	45
Surveillance mode	45
Camera image	42

Color modes	44
JCU.....	54
MFD	58
Reverse video.....	44
Scene presets.....	44
Status icons.....	42
Thermal camera.....	42
Web browser.....	48

P

Pan, tilt, zoom.....	45
Parts supplied (JCU-2).....	17
Parts supplied (M300).....	17
PoE specification	67
Power.....	
Battery connection	38
Distribution.....	37
Distribution panel.....	38
Fuse and breaker ratings.....	39
Grounding	39
Sharing a breaker.....	38
Power cable extension	39
Power connection.....	37
Power consumption.....	67
Power specification	67
Product overview	15–16
Dual payload	16
Single payload	15
Product recycling (WEEE).....	11
Product support	63

R

RayNet.....	
cables	71, 73
Reverse video	44

S

Scene presets	44
Service Center.....	63
Servicing.....	10, 60
Spares	70

Status icons	42
Surface mounting	26
Surveillance mode	45
System settings	50

T

Technical specification	66
Technical support	63
Temperature range	67
Thermal camera	42

W

Warranty	63
Water ingress	67
Web browser	
Log in	49
network connection setup	48
Overview	48
Settings	50
WEEE Directive	11

FLIR Maritime US Inc.

9 Townsend West
Nashua, NH 03063
United States of America
Telephone: (+1) 603-324-7900

Raymarine UK Limited

Marine House
Cartwright Drive, Fareham, PO15 5RJ
UK
Telephone: (+44) (0)1329 246 700



The World's **Sixth Sense**™