

Technical Specification

Operating Voltage	10-30V DC Only
Wattage	5 Watts
AMPS	12V.400 / 24V.200
Polarity Sensitivity	Yes
Lumens	300
Color Temperature (Single)	3000K or 5000K
Tri-Color	5000K / Blue / Red
Dimmable (PWM Dimming)	Yes
IP Rating	IP67
CRI Rating	80
Cutout	2 1/8 or 25.4 mm

Before You Begin

- Power Off:** Ensure that the vessel's power source and battery are disconnected or isolated before starting the installation.
- Professional Installation:** It is recommended that a qualified professional perform both electrical and mechanical installations.
- Compatible Use:** The ML-G2 Downlight is designed to function with a basic On/Off switch or it could be dimmed using the Universal Apollo Dimming module. Do not connect it to any third-party lighting control products.
- Sealing and Installation:** The ML-G2 Downlight is fully sealed which makes it perfect for indoor or outdoor installations (IP67)
- Mounting Surface:** Select a flat, level surface for installation. The Light should not be mounted on a curved surface.
- Heat Considerations:** The rear of the light may become warm to the touch. Ensure that the mounting surface is appropriate for this type of light.

Installation Diagram - Single/Dual Color On/Off Switch -

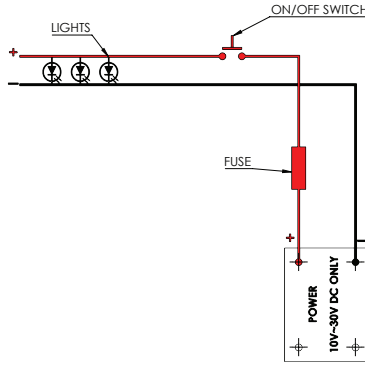

Installation Diagram - Single/Dual Color Dimmable Switch -

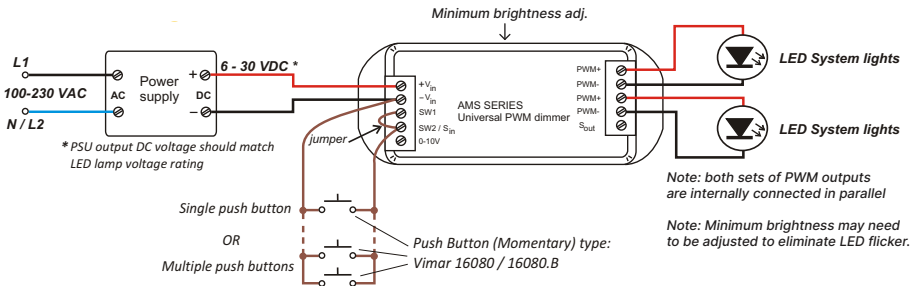

Single control input connection